

Dear user

We sincerely welcome you to become the owner of this vehicle, and thank you for your trust and love for JAC Motors. We sincerely hope that your daily life with this car will be more enjoyable because of the accompany of JAC; every journey you take will be even more exciting because of the accompany of JAC!

This vehicle, safe, cost saving and environmentally friendly, can be driven easily. It is a high-tech product that integrates all kinds of new technologies and represents the development trend of automobiles in future. Thank you for choosing this vehicle. Your choice is also significant for environmental protection.

This manual is applicable to all models of this vehicle. You may discover that the part of the devices and equipment introduced here may be not on the particular type of car you have purchased. Our company reserves the right to change the vehicle and its equipment without notice.

This manual can help you understand the composition of vehicles, driving methods, emergency measures, maintenance and so on. In order to ensure that your new car can bring you with driving pleasure, please be sure to read this manual carefully. JAC authorized after-sales service store will provide convenient and efficient maintenance services for your car. If you have any question, comment or suggestion, please feel free to contact us.

Best wishes to you and wish you a pleasant drive.

Special Instruction

Because of the constant improvement of product's quality and technology, the appearance, configuration, function and structural design of vehicles have been improved continuously by our company. The pictures, data and instructions in this manual may be inconsistent with the actual situation, and the error and negligence can hardly be avoided either, therefore, please understand and do not make them the basis of the order acceptance and legal demands. At the same time, the company reserves all rights to make changes, supplements, etc. to the contents of this manual.

The pictures in this manual are used to assist in the explanation to help you understand. Some of the pictures are for illustrative purposes only and may be limited to some models, which are not pictures of your vehicle. Please understand.

The company reserves the right to suspend the use of or change the technical specifications or design without prior notice, and we do not have to assume any obligation. This manual can not be copied, translated or excerpted without the written authorization of JAC.

This manual should be considered as a part of the vehicle. If you decide to sell the vehicle, please make sure that all materials on the vehicle will be given to the new owner.

Users' profile

Initial user

Name _____

Address _____

Tel: _____

Post code: _____

Purchasing date _____

Second user

Name _____

Address _____

Tel: _____

Post code: _____

Purchasing date _____

The safety of you and others is extremely important, so driving your vehicle safely is your important responsibility. In order to make you aware of the safety precautions, we provide explanations of the operating procedures and other matters through various signs on the vehicle and this manual. These instructions alert you to the potential dangers that could harm you or others. Of course, it is unrealistic and impossible to enumerate all operational risks. Therefore, it depends on you to make correct judgments in a timely manner. Before you read this manual, you should understand these:

Pay special attention to reading the warning and attention words in front, for they relate to important safety instructions, which are as follows:

Note:

- The text marked with this symbol in front is an important environmental protection instruction or a warm reminder.

⚠ Attention: It may cause the consequence of destroying your car or its equipment if you operate without following the instruction. Please follow the contents of attention.

⚠ Warning

- It may cause serious damage to lives of you and others if you operate without following the instruction. Please follow the contents of warning.

Direction description

All directions in the instruction manual (front, rear, left and right) are relative to the direction of the car.

Airbag Warning Label



Do not install the rear child restraint system on the seat equipped with airbag, otherwise it may cause injury or even death to the child!

Please use JAC genuine parts

● What are JAC genuine parts?

JAC genuine parts are spare parts that consistent with those in vehicles manufactured by JAC. These spare parts' design and standard can provide optimized safety guarantee for users.

● Why do you have to use JAC genuine parts?

JAC genuine parts are spare parts manufactured with strict production management and quality inspection. Any vehicle failure caused by applying mocking, counterfeit or smuggling parts will not be considered within warranty range, and JAC will not bear any responsibility for other genuine part's failure caused by reasons mentioned above.

● Please correctly identify and purchase JAC genuine parts.

Main points of maintenance

As a vehicle owner, you have the responsibility to carefully read contents concerning correct maintenance methods provided by the manufacturer, and vehicle needs more and better maintenance especially while driving in severe situations.

Precautions for oil use

Even within the warranty period, the company does not provide quality guarantee for the damage caused by the use of unqualified lubricating oil. Please use qualified lubricating oil.

Do not refit your vehicle randomly

Refitted parts are not within the warranty range of manufacturer.

Refitting may affect vehicle's safety, durability and other performance. Therefore do not try to refit your vehicle under any Circumstances.

If you need, please go to JAC authorized after-sales service store for vehicle refitting.

Slow charging



Before driving, make sure the charging cable is pulled out.
The vehicle can not be exposed to sun, rain, snow or other severe environments when being charged.

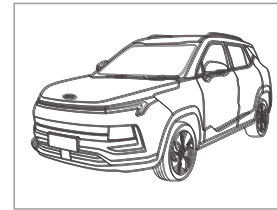
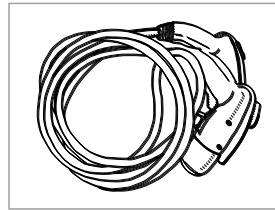
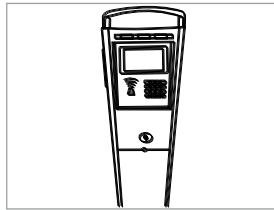

When charging with a slow charge pile, it takes about 9.5 hours for the charging status indicator changing from 15% full to its full.

Household power charging



Before driving, make sure the charging cable is pulled out.
Do not modify the charger and charging cable without permission.
Do not squeeze charging cable by the door, windows, trunk lid when charging.
Be sure to use 220V 16A and above socket (such as air-conditioning socket).

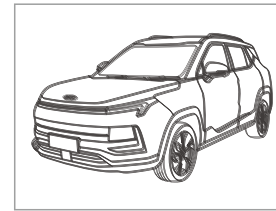
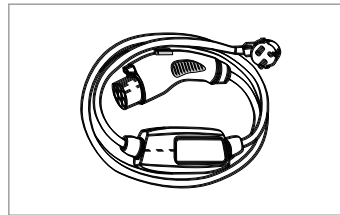
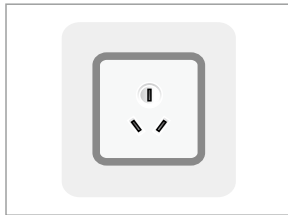

It takes more time to charge with household power.

Fast charging



Before driving, make sure the charging cable is pulled out.
Try to charge when the battery power is lower.
If not necessary, please use slow charge mode.

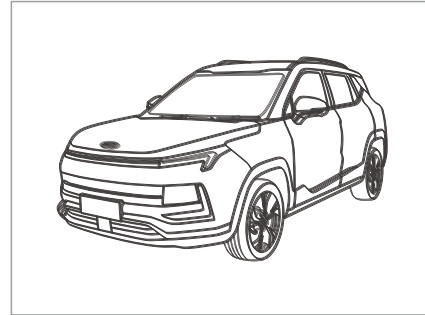
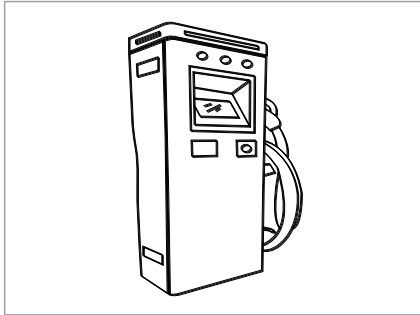

When charging with a fast charge pile, it takes about 45minutes for the charging status indicator changing from 30% full to its 80% full.



Welcome to become the owner of this vehicle

Each section begins with a detailed directory. Please look up and read through as needed.



● Chapter I Vehicle instructions.....	01
● Chapter II Vehicle description.....	09
● Chapter III Charging.....	25
● Chapter IV Safety devices--Seats and safety belts.....	41
● Chapter V Instrument and control.....	67
● Chapter VI Inspection before driving	93
● Chapter VII Ventilation and A/C system.....	117
● Chapter VIII Start and driving	127
● Chapter IX Emergency cases	173
● Chapter X Exterior maintenance.....	183
● Chapter XI Maintenance	191
● Chapter XII Technology data.....	205





1

Vehicle instructions

● Exterior body	02
● Front hood.....	04
● Cab	05
● Combination instrument	06

1

2

3

4

5

6

7

8

9

10

11

12

Exterior body

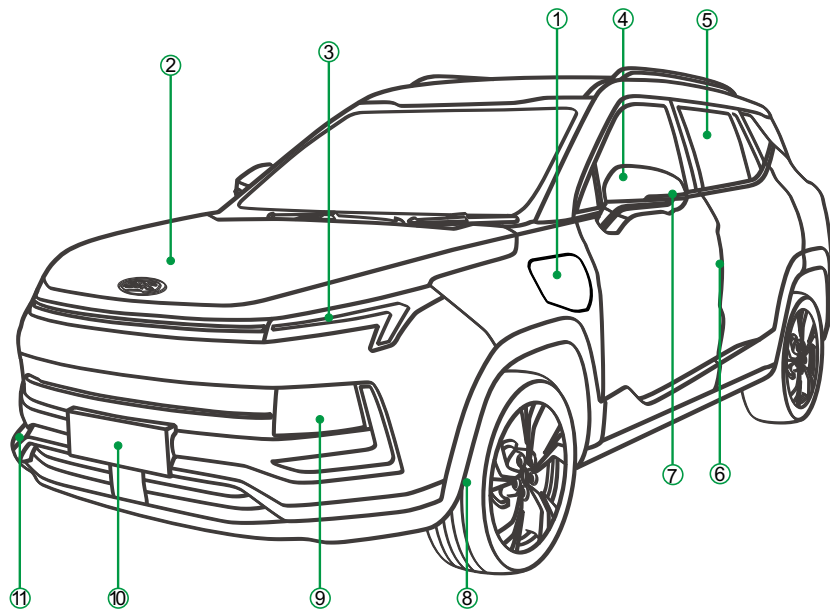

1. Integrated charging port
2. Front hood
3. Front combination lamp
4. Outside rear-view mirror
5. Power window
6. Child lock
7. Turn signal
8. Tire
9. High/low beam lamp
10. Front license plate
11. Front hook

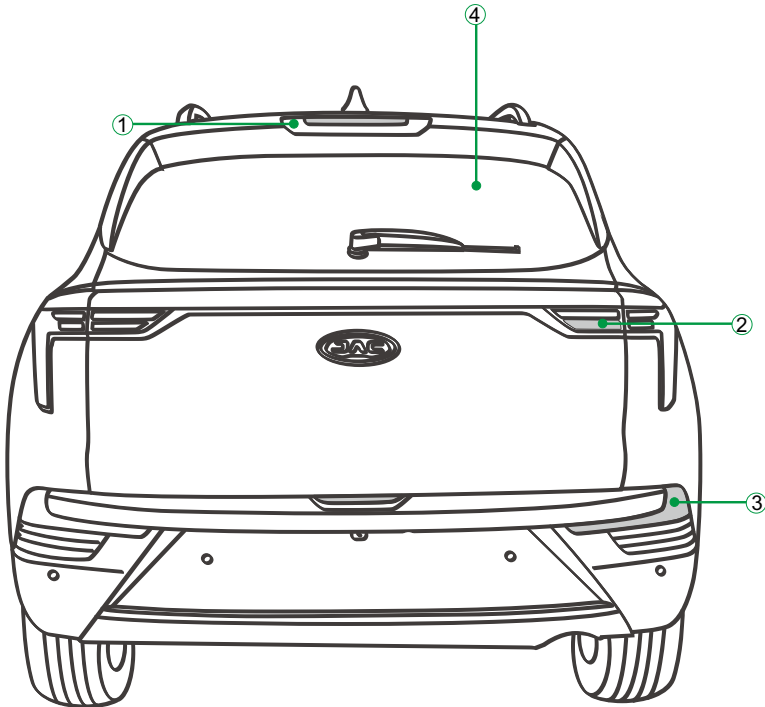

1. High brake lamp
2. Rear combination lamp
3. Rear fog lamp and retro-reflector
4. Rear windshield

1

2

3

4

5

6

7

8

9

10

11

12

Front hood

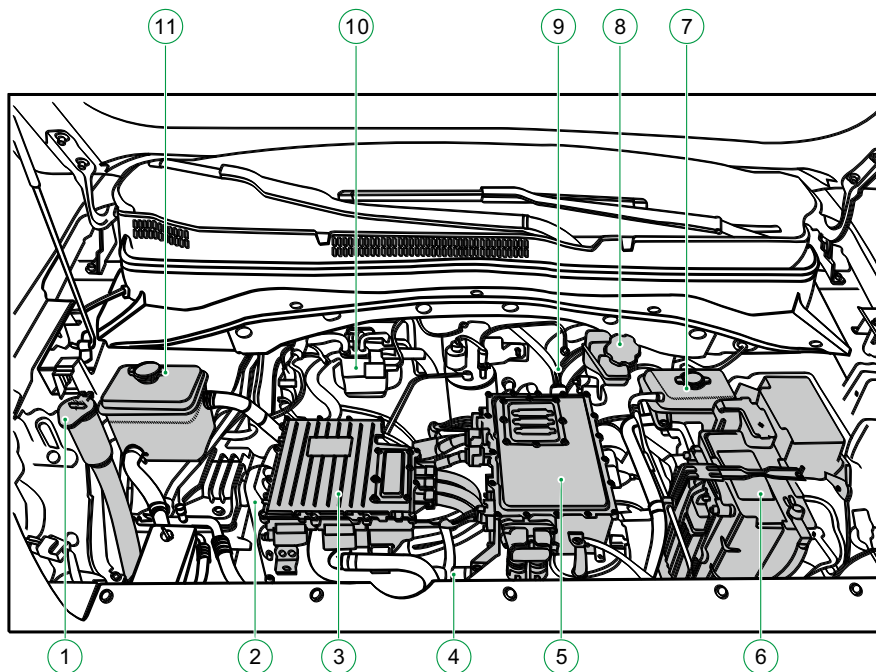

1. Washing liquid filling port
2. Air conditioning compressor
3. PCU
4. Driver motor + reducer
5. High voltage junction box
6. Battery
7. Cooling kettle
8. Brake fluid reservoir
9. Vacuum booster
10. ESC controller
11. Battery thermal management kettle



Cab

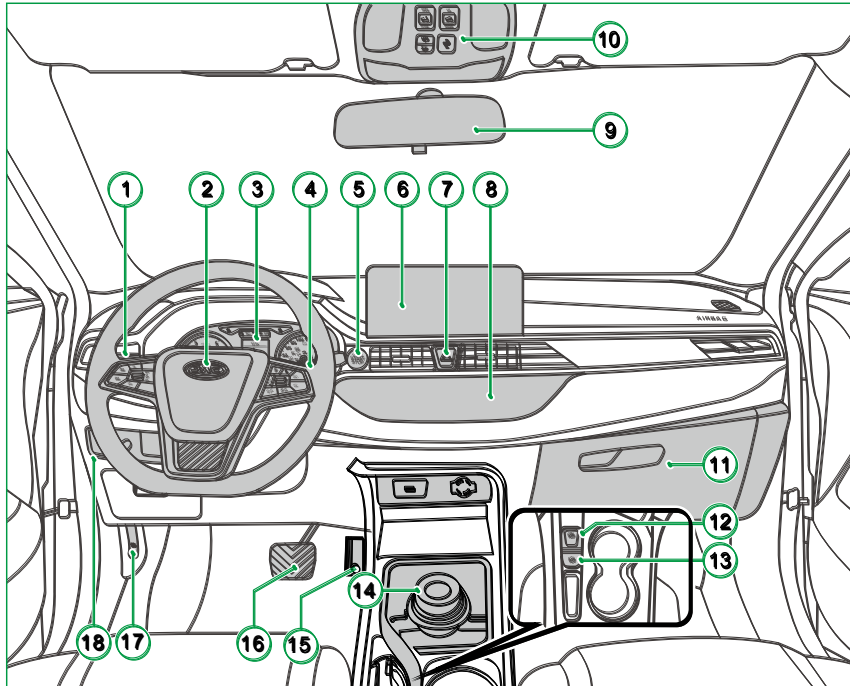

1. Lamp control lever
2. Multi-function steering wheel
3. Combination instrument
4. Wiper lever
5. Power switch
6. Multi-media display screen
7. Hazard warning lamp
8. Air conditioning control panel
9. Inner rear view mirror
10. Upper control panel
11. Storage box
12. Parking switch
13. Autohold switch
14. Shift lever
15. Accelerator pedal
16. Brake pedal
17. Front hood pull handle
18. Left lower switch group

1

2

3

4

5

6

7

8

9

10

11

12

Combination instrument

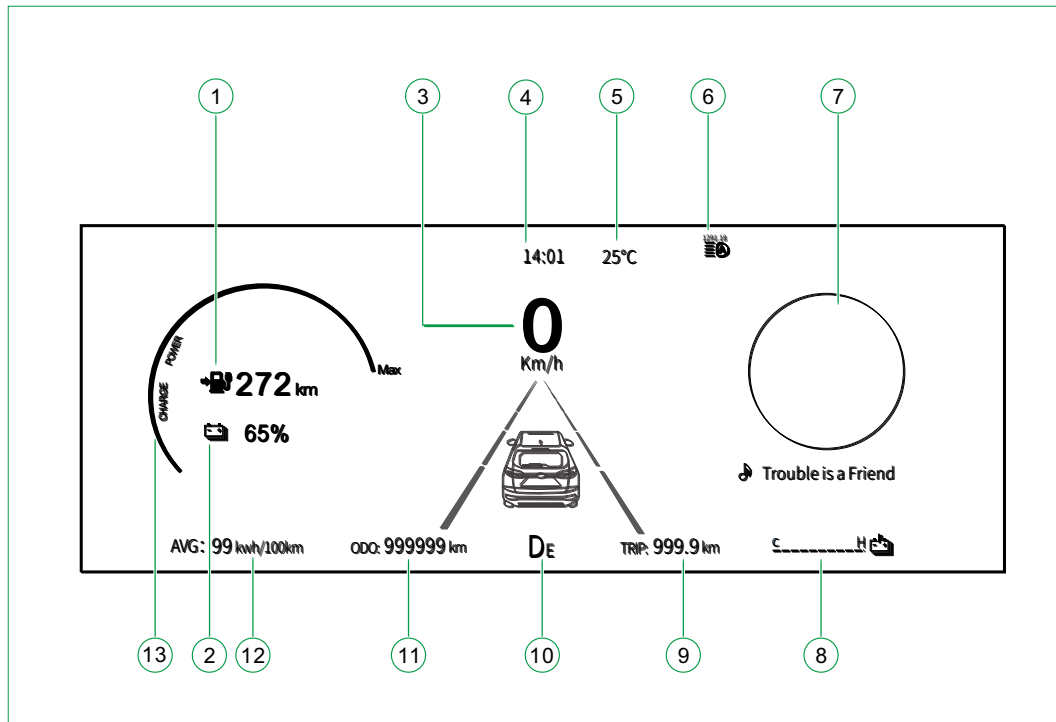







1. Endurance mileage
2. Power battery power meter
3. Speedometer
4. Time
5. Temperature
6. Indicator light
7. Menu, sub-function
8. Power battery thermometer
9. The subtotal mileage
10. Gears
11. Total mileage
12. Average power
13. Power meter



Serial No.	Icon	Description	Serial No.	Icon	Description
1		Left turn indicator	20		Vehicle stability system off indicator (if configured)
2		Far-beam indicator	21		Vehicle stability system working indicator (if configured)
3		Low-beam indicator	22		Motor fault warning light
4		Right turn indicator	23		Power battery off indicator
5		Rear fog lamp indicator	24	TPMS	TPMS fault warning lamp
6		Charging cable connection indicator	25		System fault warning lamp
7		Charging status indicator	26		Position lamp indicator
8		Parking indicator and brake system malfunction warning lamp	27		Co-driver's seat belt warning lamp
9		Power battery fault warning lamp	28		Driver's seat belt warning lamp
10		12V battery fault warning lamp	29		Safety airbag fault warning lamp
11		EPB fault warning light	30		BSD fault indicator
12	AUTO HOLD	AUTOHOLD indicator	31		Battery charging state indicator
13		Limited power indicator	32		HMA indicator (Yellow/Green)
14		CCS indicator	33		Electronic gear failure warning light

- 1
- 2
- 3
- 4
- 5
- 6
- 7
- 8
- 9
- 10
- 11
- 12

Vehicle instructions

Serial No.	Icon	Description	Serial No.	Icon	Description
15		Power steering system fault warning lamp	34		LDW indicator (Yellow/Green/White)
16		ABS fault warning lamp	35		Front collision warning system indicator
17	READY	Driving status indicator			
18		Pedestrian warning system fault indicator			
19		Abnormal tire pressure warning lamp			



2

Vehicle description

● Power battery	11	Parking.....	21
● Power battery discharge	11	Charge after parking	21
● Power battery temperature control device	12	● Good habits	22
● Precautions of high-voltage safety.....	13	Driving range	22
● Notes for vehicle collision	14	Methods to extend the driving range.....	22
● Emergency shutdown of high-voltage system	16	● Power battery's lifespan.....	22
● Electric vehicle's features	16	Methods to extend the power battery's lifespan.....	23
● Electric vehicle's main functions	17	● Electric vehicle's specific information.....	23
Charging methods and information.....	17	Pedestrian warning system	23
Charging time	18	Shift control mechanism.....	24
Start the car.....	18	P-gear.....	24
Driving.....	19		

Pure electric vehicle profile

The car is a pure electric vehicle. The working principles and characteristics of many parts and systems are very different from the traditional fuel vehicles. Therefore, it is important to read the instructions in this manual for your personal safety and the safety of your car. Ignoring these instructions may have serious consequences for the safety of the driver and passengers and the performance of the vehicle. It may also result in the loss of your warranty or repair rights.

The car is powered by pure electricity instead of the engine, which is the main difference with the traditional fuel vehicles. The car uses lithium-ion power battery to store electric energy and the power battery must be sufficient before driving. During the vehicle driving process, the battery is gradually discharged. When the power battery is low, it must be charged, otherwise the vehicle can not drive. The vehicle has two charging methods: slow charge and fast

charge. Slow charge includes slow charge of standard charging post and slow charge of household power supply. Each slow charge includes two modes: normal mode and macrobian mode.

The car is equipped with two kinds of batteries, one is a lithium-ion battery (high voltage), which is used for driving by supplying power to the drive motor; the other is a 12V lead-acid battery, which is arranged in the front compartment and whose function is the same as the one on the traditional fuel vehicle for car headlights, audio, speakers and other low-voltage electrical systems. The 12V lead-acid battery's power is from the driving battery.

The car is connected to the power grid using a charging plug to charge the battery. In addition, when the car slows down or brakes, energy will be stored in the power battery through the electricity generation of the motor, thereby extending the vehicle's driving range, which is called energy recovery.

The vehicle has a creep function, that is, when the vehicle is in a driving state (READY state), put the shift lever in the "D" gear (forward) or "R" gear (reverse), release the brake pedal, acceleration pedal and parking switch, the vehicle will creep. The car has two driving modes, standard mode and ECO mode.

- Standard mode. The vehicle accelerates smoothly and steadily after lightly pressing the acceleration pedal; energy is recycled when the vehicle is taxiing or you step on the brake pedal.

- ECO mode. Generally you only need to control the acceleration pedal to achieve vehicle acceleration, deceleration, taxiing and energy recovery. When in acceleration, the acceleration pedal is required to a certain degree of opening; when in deceleration, slowly release the acceleration pedal, the smaller the pedal opening, the stronger the deceleration, and the vehicle will have greater energy recovery. When in emergency braking, you still need to depress the brake pedal.



Power battery

Warning

- Your vehicle contains a confined series of high-voltage lithium-ion batteries. If the power battery is not properly exposed, there is a risk of serious burning and electric shock, which may result in serious injury and death and environmental pollution.

 **Attention:** In order to avoid damage to the battery, please observe the following points:

- Do not place the vehicle in a high temperature environment over 45 °C for more than 1 day, and you should timely place the vehicle in a cool environment.
- Do not store the vehicle at -20 °C for more than 3 days. Place the vehicle in a warm environment in time.
- When the battery power is lower than 10%, the vehicle may not be parked for more than 14 days, and the vehicle should be charged in time.
- Do not use the power battery on the vehicle for other purposes.

Note:

- If the outside temperature is below -20 ° C, the interior of the battery may freeze, rendering it uncharged and unable to provide power to the vehicle. Please promptly place the vehicle in a warm environment.
- Long-term use or abuse will affect the battery performance and service life, which will lead to reduced driving range.
- Battery capacity decay rate will change with the user's usage, and the degree of change depends on the vehicle and battery usage.

Power battery discharge

The meter shows the SOC value and MP5 shows the referenced remainder mileage; the value is of a great influence by driving habits, for reference purposes only:

1. When the state of charge (SOC) is less than 15%, the SOC value flashes on the meter, to remind the remaining battery power is limited; when the SOC is less than 10%, SOC value is displayed as "--", indicating that the remaining power has been very limited, it is recommended to charge as soon as possible.

1

2

3

4

5

6

7

8

9

10

11

12

2. When the limited power indicator (turtle lamp) is lit, the vehicle output power is limited and the speed drops. Possible causes of power limitation: Insufficient power battery, overheating of the power battery, undercooling of the power battery, and large voltage drop of the power battery; it is recommended to park the vehicle in a safe area as soon as possible before the battery power is exhausted, which affects driving.

Power battery temperature control device

▲Attention: To avoid that the external environment temperature is too high or too low that causes damage to the power battery:

- Do not park the vehicle in an environment where the ambient temperature exceeds 45 °C for more than 1 day;
- The power battery heating device is only turned on when the charging cable is connected. Therefore, when the charging cable is not connected, do not park the vehicle when the ambient temperature is below -20 °C for more than 3 days.

Power battery cooling device

The power battery has a cooling device, which ensures that the power battery has a good operation temperature under a high temperature environment. When the power battery temperature exceeds the limit, the cooling device will automatically start working; when the power battery

temperature backs to the normal range, the cooling device is automatically shut down.

Power battery heating device

As the capacity of power battery can be reduced when being charged or discharged in low temperature environment, the battery in this vehicle has a heating device, which can ensure that the battery has a suitable temperature under low temperature environment.

▲Attention: - The heating device is turned on automatically when the battery is charged and the temperature of the power battery is lower than a certain value.

- Charging time will be extended when heating device starts;
- In cold conditions, in order to ensure the driving range of the vehicle, you can choose the winter warm-up function before traveling. However, this function consumes electricity and it is recommended to use it when the charging cable is connected.



Precautions of high-voltage safety

High-voltage parts

Warning

- Vehicle voltage platform is within 400V, please do not touch the high-voltage components without breaking the high voltage. The high-voltage components of the vehicle include: drive control device, high-voltage power distribution device, car charger, high voltage main cable, fast charging plug, fast charging socket, power battery, battery heater, driving motor, slow charging plug, slow charging socket and so on.
- The surface temperatures of the driving motor, the driving control device and the electric vacuum pump are higher when the vehicle is running for a period of time. If the air conditioning is in refrigeration, the electric air conditioner compressor's and the radiator's surface temperature are higher; in the vehicle charging process, the car charger's

surface temperature is higher. In these cases, do not touch the above parts in bare hands.

- It is forbidden to disassemble the high-voltage electrical components, unplug or disconnect the high-voltage connectors and cables in the car without permission. Otherwise, it may cause serious electric shock damage and vehicle damage. The high voltage cables in the car are wrapped with orange and yellow bellows, needing your attention for identification.

1

2

3

4

5

6

7

8

9

10

11

12

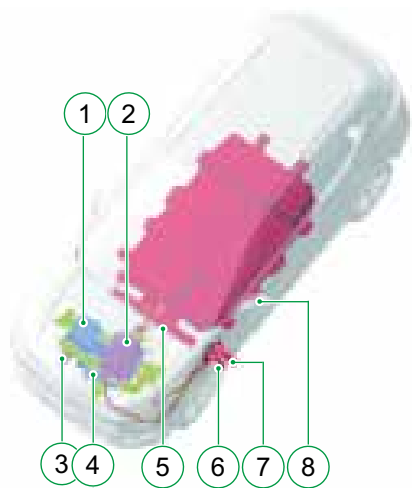

- | | |
|--------------------------------|----------------------------|
| 1. Motor controller | 5. High voltage main cable |
| 2. High voltage junction box | 6. Slow charge socket |
| 3. Air-conditioning compressor | 7. Fast charge socket |
| 4. Drive motor | 8. Power battery |

Notes for vehicle collision

Warning

- If the vehicle collides (including front, rear, left and right collisions and ground impact):
 - Even if the vehicle can still be running, it should also be parked safely; pull the parking switch, the vehicle is power off, and do not touch the body metal.
 - In any case, it is forbidden for any person to maintain the vehicle while the vehicle is not fully powered off.
 - Check whether the vehicle high-voltage components and wiring harness are damaged or bare (high-pressure parts layout can be used to determine the location of components). To avoid personal injury, do not touch high-voltage wiring harness, connectors, and other high-voltage components (PCU, power batteries, etc.).
- Do not touch broken, exposed wiring harness to avoid the danger of electric shock. In particular, when the chassis scratches the ground, you should carefully



check the distribution of high-voltage wiring harness on the floor for damage. If you need to touch any high-voltage cable or component, wear insulated protective clothing (including insulated gloves, insulated shoes, insulated clothing) with a withstand voltage of 1000V or more.

- If you can not estimate the extent of vehicle damage, do not touch the vehicle. You should be away from the vehicle and immediately contact JAC authorized after-sales service store to inspect and repair the vehicle; be sure to inform the emergency personnel who came to deal with the accident as soon as possible that the vehicle is an electric vehicle, and no one else shall approach, touch or move the vehicle.
- If the occupants are trapped and can not disconnect the high-pressure maintenance switch, try to cut the vehicle after confirming with the professional personnel. Do not touch the high-voltage cable during cutting (the surface of high-voltage cable is yellow or orange).

- It is forbidden to disassemble the high-voltage wiring harness and high-voltage components in the front compartment without permission. The surface of the high-voltage wiring harness is yellow or orange.
- Leaking or damaged battery power may cause a fire. If it happens, please contact JAC authorized after-sales service store immediately. Please do not touch the leaking electrolyte; if skin or eyes inadvertently contact with the electrolyte, rinse immediately with plenty of water and seek medical advice immediately to avoid injury.
- If the vehicle is in a fire, immediately leave the vehicle and be sure to use a water-based fire extinguisher to extinguish the fire. Using a small amount of water or non-specified types of fire extinguishers can cause serious injury or death. For trailer, be sure to raise the front wheel away from the ground. Because if the front wheels are on the ground when being towed, the drive motor may generate

electricity, causing damage to high-pressure parts of vehicles and even causing a fire.

- If the vehicle needs repair or painting after impact, it must be handled by the JAC authorized after-sales service store and shall not be disassembled without permission. The power battery, high voltage wiring harness, motor controller and other high-pressure components should be removed before paint spraying. As the power battery is exposed to the spraying operation at a higher temperature, it may affect the power battery's lifespan. In addition, if the car's power battery is not removed, it may pose a safety hazard for maintenance personnel without professional training of electric vehicle maintenance.
- In the event of a vehicle malfunction or an accident, please immediately place the triangular warning sign at about 100m in the rear of the vehicle, but about 150m in the rear of the vehicle on the expressway, warning passing vehicles or pedestrians to avoid risks.

1

2

3

4

5

6

7

8

9

10

11

12

Emergency shutdown of high-voltage system

When the following conditions occur, the vehicle will automatically cut off the high-voltage system.

1. Vehicle collision and airbag open;
2. Electric system failure;

If a collision occurs, the electric system fails, causing the high-voltage system to open, the driving status indicator (READY lamp) will go out and the vehicle can not continue driving. Please contact JAC authorized after-sales service store immediately.

Electric vehicle's features

Warning

- Pay particular attention to pedestrian safety because electric vehicles do not have engine noise and pedestrians may not know when the vehicle is approaching.
- When leaving the vehicle, be sure to turn off the power switch and turn off the high-voltage system.
- When leaving the vehicle, be sure to put the gear in "N" position (Neutral) and pull the parking switch to avoid accidental movement of the vehicle.
- In the READY state and the gear is in the D or R range, be sure to depress the brake pedal or the vehicle will creep, causing an accident or injury.

Note:

- When the vehicle is charged in low temperature environment (such as 0 °C), the charging time will increase.
- When the vehicle is driving in low temperature environment (such as 0 °C), the vehicle's power performance and driving range will decline.
- When the battery power is low (such as 10%), the power performance and driving range of the vehicle will decrease.
- With longer use time and battery abuse, vehicle's power performance and driving range will be reduced.
- The car is driven by the electricity from the power battery; frequent acceleration consumes more battery power than driving with a steady speed.
- The car is equipped with energy recovery function. When taxiing or braking, the motor converts the vehicle's kinetic energy into electrical energy stored in the battery. It is a normal phenomenon that there is a slight sense of frustration and motor noise when the taxiing or braking distance decreases.



- When power battery is fully charged, in order to prevent overcharge, energy recovery will be automatically reduced. When the temperature of the power battery is too high or too low, energy recovery is also automatically reduced in order to prevent damage to the battery.
- Depending on the road or traffic conditions, the brake pedal slows or stops the vehicle. Braking system is not affected by energy recovery.

Noise and vibration

Noise and vibration of the electric vehicle are different from the traditional fuel car. The following noise and vibration are normal:

1. Running noise of the motor and reducer.
2. Running noise of electric air conditioner compressor and cooling fan.
3. Electric vacuum pump noise.
4. Noise and vibration of relay opening or closing when starting or shutting off high-voltage system.
5. Pedestrian warning system's working sound.
6. Running noise of pump and cooling fan in charge state.

Electric vehicle's main functions Charging methods and information

Warning

- The high-voltage system will be charged with high voltage and large current, please strictly follow the instructions, otherwise it may cause serious casualties. Before charging, please read "Chapter III Charging" carefully.

Charging methods

The vehicle has two charging methods: slow charge and fast charge.

1

2

3

4

5

6

7

8

9

10

11

12

Vehicle description

Charging time

The charging time depends on battery SOC, power supply, ambient temperature and battery's durable years. The charging time in this manual is only a nominal value, which may differ from actual time.

The car needs electric energy to be driven and the power battery is its only power source. When you are driving, the power of the battery is gradually reduced. A planned charge is very important to prevent the vehicle from driving due to the complete power battery loss.

Start the car

Without stepping on the braking pedal, press the power switch once, the vehicle will be placed to the ON; the instrument background lamp and part of the indicators that need to be self-test will be lit; the whole vehicle's low voltage and high voltage will be connected.

Step on the brake pedal and press the power switch, the READY lamp on the instrument will be lit, and the vehicle will be ready to drive.



Warning

- Do not press the power switch continuously.

Note:

- If you press the brake pedal and press the power switch, READY lamp is not lighted up, please restart.
- Before driving, please check the instrument power battery meter or check the referenced remainder mileage displayed on the MP5 to confirm whether the power battery can meet the driving demand. If the battery power is insufficient, please charge it in time.
- The shift of vehicle from off to start should not be too fast, and two intervals shall be greater than 10 seconds.



Driving

1. Depress the brake pedal and hold it, shift gear from N to D, the instrument and the MP5 will show "D".
2. Put down the parking switch.
3. Release the brake pedal, the vehicle begins to creep; lightly step on the acceleration pedal, the vehicle begins to travel.
4. Gradually depress the acceleration pedal for acceleration; maintain the acceleration pedal to a certain degree of opening for driving with an even speed.
5. Depress the brake pedal for braking.
6. For reversing, depress the brake pedal until the vehicle is parked completely and remain it stationary; shift gear to R; release the brake pedal, the vehicle begins to creep, lightly step on the acceleration pedal, the vehicle begins to reverse.
7. If ECO mode needs to be used, You can turn on the ECO mode through the central control screen "Vehicle Settings>Car Settings>ECO". "DE" will be displayed on

the instrument and MP5. At this moment, the acceleration pedal can be used to accelerate, decelerate, slide and recycle energy. In acceleration, the acceleration pedal is required to a certain degree of opening; in deceleration, slowly release the acceleration pedal, the smaller the opening of the pedal, the stronger the deceleration, and the vehicle will have greater energy recovery. In emergency braking, you still need to depress the brake pedal.

Warning

- Do not driving vehicle after drinking alcohol.
- Accidental vehicle movement may result in serious injury.
- It is forbidden to power off during driving.
- It's forbidden to step on the acceleration pedal in shifting nor can you shift gear when you are stepping on the acceleration pedal to prevent the vehicle from being out of control.
- When shifting or parking, please observe the display of information on the instrument or MP5, to confirm whether it is your desired position.
- Please don't press brake pedal and acceleration pedal at the same time.
- Emergency braking should be avoided in the course of vehicle driving.
- The vehicle should be slowed down as much as possible during turns, and sharp turns are forbidden.
- For safety reasons, don't climb steep slopes.
- When the vehicle is in the READY state, shift lever is in D or R, and you are planning to park, be sure to step on the

1

2

3

4

5

6

7

8

9

10

11

12

brake pedal or pull up the parking switch, otherwise the vehicle will creep; If you leave the vehicle, be sure to pull the EPB and put the gear in P.

- For ramp parking, you can step on the brake pedal or pull up the EPB to keep the vehicle still instead of stepping on the acceleration pedal to stop the car.

- The vehicle has the active safe ramp start assist function. When the vehicle is going uphill, loosen the acceleration pedal, the vehicle will be stopped automatically on the ramp, then step on the acceleration pedal, the vehicle will start running steadily.

- Avoid the vehicle driving in deep water. If the vehicle must pass the road with water, the wading depth shall not exceed the edge under the vehicle body and you should drive at a low speed.

- Do not open the front hood when the vehicle breaks down or an accident happens in rain.

- In vehicle driving process, if the bottom of the car is seriously scratched, please contact JAC authorized after-sales service store.

Note:

- The vehicle has a creep function, that is, when the vehicle is in the READY state, the gear is in D or R, the brake pedal is released, the parking brake is released, and the vehicle creeps when the accelerator pedal is not depressed.

- During vehicle's start-up or driving, the vacuum pump in the front compartment will work intermittently and the vacuum pump will emit a "buzzing" sound, which is normal.

- Frequent rapid acceleration of vehicles may reduce the power performance, which is a normal phenomenon.

- Drive carefully on a raised pavement or a place with fixed limit block.

- During driving, please charge as soon as possible if the SOC on the instrument is less than 15%, the charging status indicator  is on, and the remaining mileage is about 20km. If the SOC is less than 10%, the battery power meter displays "--", and the power of battery is about to run out, you must charge it as soon as possible.

- The car has a standard mode and an ECO mode.

Generally you only need to control the acceleration pedal to achieve vehicle acceleration, deceleration, taxiing and energy recovery. When in acceleration, the acceleration pedal is required to a certain degree of opening; when in deceleration, slowly release the acceleration pedal, the smaller the pedal opening, the stronger the deceleration, and the vehicle will have greater energy recovery. When in emergency braking, you still need to depress the brake pedal.



Parking

1. Park the vehicle on the right road.
2. Depress the brake pedal until the vehicle is stopped slowly, and keep it still.
3. Parking.
4. Put the gear in N.
5. Release the brake pedal.
6. Press the power switch to power off.
7. If it needs to be charged after parking, please refer to "Chapter III Charging".

Warning

- Improper parking can result in serious injury.
- When parking or stopping, be sure to put the gear in N position and pull the parking switch to prevent the vehicle from moving accidentally.
- Never leave children or people with mobility problems in the car. They may release the parking switch and operate the shift lever, causing the vehicle to move, leading to an accident and serious injury.

▲ Attention: Parking carefully in the place with fixing stopper or blocks, otherwise the vehicle bumpers and other parts may be damaged. Please park the car before the wheels touch those stoppers.

Note:

- Take the key when leaving the car.

Charge after parking

When you arrive at the destination, it is recommended to charge immediately, see "Chapter III Charging."

1. Press the power switch to power off. Open the charging port cover and the charging port protection cover.
2. Use the charging cable to connect the vehicle and charging power supply.
3. After the charging cable is connected, the vehicle will emit a "beep" sound, the charging indicator will turn yellow, and the charging cable is connected normally; then the "beep-beep" sound will be heard twice, the charging indicator will change from yellow to green, charging begins.
4. After power battery is full, the charging indicator flashes off.

1

2

3

4

5

6

7

8

9

10

11

12

Vehicle description

Good habits Driving range

Driving range depends on the vehicle speed, vehicle load, driving condition, temperature, battery's power and power battery's using years and many other factors. The actual driving range may be between 200- 350Km.

Methods to extend the driving range

Before driving:

- Periodic maintenance.
- Check whether the tire pressure is normal.
- Check whether the four-wheel positioning parameters are normal.
- Remove unnecessary luggage or goods.

Driving:

- Maintain a steady speed.
- Slow and steady acceleration.
- Keep a safe distance with the front car and avoid frequent braking.
- Set the appropriate temperature for air-

conditioning cooling or heating, in order to reduce the battery power consumption.

- Turn off air conditioning if not necessary.
- As far as road traffic permits, please slow down by releasing the accelerator pedal, and try not to depress the brake pedal.

The car is equipped with energy recovery; when braking or taxiing, it recycles vehicle kinetic energy to charge the power battery, extending the driving range.

Power battery's lifespan

With the increase of usage years and charging times, power battery capacity will decline and driving range will decline, which is a normal situation rather than the vehicle or battery failure.

Vehicle driving range and power battery capacity are affected by driving habits, storage conditions, charging methods, battery temperatures and other conditions.



Methods to extend the power battery's lifespan

It is recommended to follow the following driving habits and charging methods as much as possible:

- Do not place the vehicle in a high temperature environment of 45 °C for more than 1 day;
- Do not place the vehicle in a low temperature environment of -20°C for more than 3 day;
- When the battery power is lower than 10%, the vehicle may not be parked for more than 14 days;
- Charge immediately after parking in winter;
- In summer, please park your car in a cool environment, and try to avoid direct sunlight and keep away from heat;
- Use slow charge as much as possible with macrobian mode; use less or seldom use the long range mode or fast charge mode;

- When the battery power is greater than 80%, it is not recommended to charge;
- Smooth driving;
- If the vehicle is placed for a long time:
 - Power battery's power shall be kept at 50% - 60%;
 - Disconnect the 12V lead-acid battery negative;
 - It is recommended to charge once with macrobian mode every month; please connect the 12V lead-acid battery negative before charging.

Electric vehicle's specific information

Pedestrian warning system

The function of the pedestrian warning system is to make a sound to remind pedestrians when the vehicle is traveling at a low speed. When the vehicle starts charging, it makes a sound. When the vehicle is running within 20km / h, the system makes a sound. When the vehicle is reversing, the system makes a sound. When the charging cable is connected, the system sends a "beep"; when charging starts, the system sends out "beep" twice.

Warning

- If pedestrians do not hear the beep of the system, they will not notice that there is a vehicle approaching them, which may cause traffic accidents and pedestrian injuries.

1

2

3

4

5

6

7

8

9

10

11

12

Vehicle description

Shift control mechanism

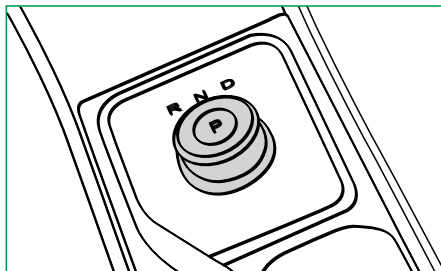

The vehicle adopts a knob-type shifting control mechanism, with 4 gears: "P" (parking gear), "R" (reverse gear), "N" (neutral gear), and "D" gear (drive gear) . The vehicle can be powered off in P/R/N/D gear, and the vehicle will automatically enter the "P" gear after power off. When the start switch is in "ACC", the vehicle automatically enters the "P" gear and cannot switch gears. After the vehicle enters the "READY" state, it will automatically enter the "P" gear. If you want to change gears, please depress the brake pedal at the same time (vehicle speed is 0km/h).

P-gear

When the vehicle is powered on to READY state, the working indicator of parking switch will be lit, displaying P on the the instrument. When the effective shift (D/N/R) is put in, the parking state will be released, the working indicator will display the corresponding gear position instead of P gear.

Note:

- At this time, the EPB is in working state. The EPB indicator lights up, fasten the driver's seat belt, then step on the acceleration pedal, the EPB is released, and the EPB indicator is turned off.
- When the vehicle is powered off or the driver's door is opened in the static state, the vehicle will switch to the parking state actively and the EPB will work. Meanwhile the indicators of the P-gear switch and the EPB switch will work.
- The EPB can not be released in the P-gear.

Warning

- When the vehicle needs to be in gear P when parking, step on the brake pedal and press the gear P switch. The indicator will work and the gear P will be displayed on the instrument.
- Do not press the P gear during non-emergency driving. When the vehicle speed is no more than 7km/h, long press P gear or brake with short pressing P gear, the vehicle will switch to P gear, EPB will work at the same time, and the p-gear switch and EPB switch working indicator will light up, but this operations is dangerous and may cause traffic accidents. When the vehicle speed is more than 7km/h, short press P gear, the EPB will not work, but the instrument indicates "Unable to park"; Long press P gear, the vehicle will slow down at a certain speed, but it can not replace the function of brake.



3

Charging

● Precautions for charging	26
● Charging methods	28
● Opening and closing the charging port cover	28
Charging time.....	30
Slow charge.....	30
Fast charge	35
● Charge indicator.....	37
● Charge at low temperature	37
Power battery heating device	37
● Charging troubleshooting guide.....	38

1

2

3

4

5

6

7

8

9

10

11

12

Precautions for charging

Warning

- If you are using an electronic medical device, such as a cardiac pacemaker or a cardiovascular defibrillator, please verify that the charge of the electric vehicle has an impact on the device before charging. Charging may affect the functionality of the electronic medical device.
- If you have a cardiac pacemaker or cardiovascular defibrillator, take note of the following points when charging:
 - Do not stay in the car.
 - Don't go into the car to get anything.Charging may affect the functionality of the electronic medical device, resulting in personal injury or death.
- The charging temperature of the vehicle is recommended between 0 °C -35 °C, to avoid charging in low temperature or high temperature environment (it is recommended at noon in winter, in the morning and evening in summer).
- Please check whether the skin of the charging cable and the shell are

damaged before charging, if any of them is damaged, please contact JAC authorized after-sales service store for repair or replacement; using damaged charging cable is prohibited.

- Charging plug is a high-voltage electrical device, which is forbidden to children. Children's operation is strictly prohibited in charging process.
- Before charging, if the vehicle has been driven in the rain, please wipe the body near the charging port, and then open the charging port to charge.
- Please confirm the charging port and charging plug are free of water or other debris, rust or corrosion. If there is water or rust on the charging port or charging plug, please do not charge it to avoid short circuit or electric shock or even injury.
- Power supply equipment, vehicles to be charged, charging cable and charging plug should be kept away from rain, snow and stagnant water, and they can not be close to the fire.
- Please keep the charging port dry and clean during charging, if necessary, take

appropriate precautions.

- In case of sudden changes in the weather (gale, rain and snow) in the charging process, you should promptly check whether the charging plug is solid and dry; when it is lightning, it is not allowed to touch the charging cable and the body.
- If it is damp near the charging port during charging, please disconnect the power supply first when safety can be ensured and then disconnect the power supply plug (Do not touch the charging plug metal sheet with the hand or other parts of the body to avoid accidents caused by possible charging system's malfunction) , then pull out the car charging plug. If necessary, please use insulated gloves, and contact JAC authorized after-sales service store for confirmed inspection.
- There may be sparks inside the charging system during operation. Do not use the charging device in the environment where gasoline, paint, flammable liquids are used or stored.
- During the charging process you should



take appropriate protective measures; try to keep children and other non-related personnel away from charging vehicles and charging cables.

- It is forbidden to insert slow charging plug and fast charging plug at the same time.
- Do not squeeze the charging cable when charging, to avoid electric shock or fire.
- During charging, make sure the charging cable is in a state of natural extension. Do not hang it in the air.
- When charging, the charging cable is prohibited in the car.
- When charging, the charging cable must be far away from the fire.
- When charging, do not approach or touch the front compartment cooling fan;
- Precautions for charging:
 - Do not touch the metal part of charging socket and plug;
 - It is prohibited to touch electric vehicle or any device when sparks occur in electric vehicle or vehicle charger. Otherwise, there will be electric shock, causing personal injury.
- When using household power supply, be sure to use 220V 16A and above

specifications of the socket (such as air conditioning outlet).

- The household power supply equipment used to charge the vehicle needs to be confirmed by a professional electrician who has a national vocational qualification certificate.
- Try to avoid direct sunlight and other high temperature charging environment in summer.
- If you find a special smell or smoke in the car, immediately and safely cut off the power supply.
- Do not use wet hands or stand near water, liquid or snow to plug or unplug the charging plug. Otherwise, electric shock may occur and cause casualties.
- When unplugging the charging plug, please hold the insulated part of plug for operation. It is forbidden to directly drag or pull the charging cable.
- Do not disassemble or modify the charging port without permission.
- It is forbidden to prolong or modify the charging cable or plug separately, otherwise it will be prone to danger.

- ⚠ Attention:** To prevent charging system failure, please take note of the following points:
- Please turn off the vehicle charging socket protective cover, and then turn off the charging port cover;
 - Avoid collision to the charging plug;
 - Avoid squeezing the charging cable;
 - Do not pull or wrap the charging cable;
 - Do not put charging cables near heaters or other heat sources. After charging, please make sure to close the charging socket protective cover and charging port cover.
- Before starting the vehicle, make sure that the charging plug is unplugged from the charging port, otherwise the vehicle will not start.

1

2

3

4

5

6

7

8

9

10

11

12

Charging

Note:

- Before charging, please power off the vehicle; when the vehicle is powered on or in the READY state, it can not be charged.
- When the ambient temperature is low or high, the charging time may be extended.
- If the vehicle is not used for a long time, it is recommended to use slow charging, and charge it at least once a month.

When the power battery is out of power, please charge it immediately.

- The vehicle has two charging methods: slow charge and fast charge. Please select the appropriate charging method to minimize the frequency of fast charge.
- When being charged, the vehicle can not be READY and can not run.
- The power battery has a thermal management system. If power battery temperature is too high when it is being charged, the thermal management system will automatically turn on cooling (even if the vehicle is not powered), the condenser fan will work; when the power battery temperature decreases, the thermal management system will be shut down automatically. When the power battery temperature is too low, the thermal management

system will automatically turn on heating.

When the power battery temperature increases, thermal management system will be shut down automatically.

- If the power supply is interrupted during charging, the vehicle will be stopped being charged. For the charging equipment without a card, it will enter common mode charge after the power supply is restored.
- If the charging port freezes, use a hair dryer to melt the ice and wipe it clean before recharging. If it is forcibly connected, the charging plug may be damaged.
- If foreign matter is going into the charging port or charging plug, they will not be connected, please do not forcibly operate them. Please contact JAC authorized after-sales service store to deal with it. Forcing connection of the charging plug and the charging port may damage the charging equipment and the vehicle.
- If you need to lengthen the charging cable, JAC authorized after-sales service store can provide 10m or 20m dedicated charging cable for you to purchase.

Charging methods

The vehicle has two charging methods: slow charge and fast charge. Slow charge includes slow charge of standard charging post and slow charge of household power supply.



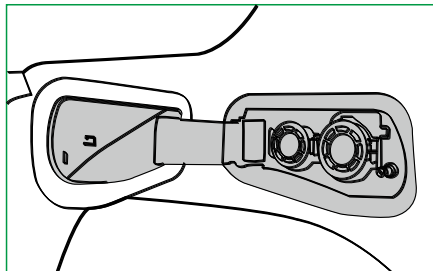



Opening and closing the charging port cover

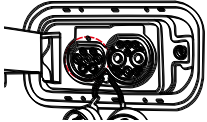
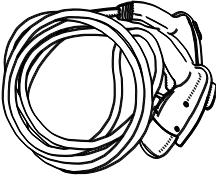

The vehicle charging port is on the front left side panel of the vehicle body. When the vehicle is unlocked, press the right edge of the charging port cover, you can hear a slight "click" sound, the charging port cover will automatically pop open;

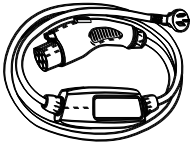

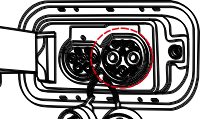
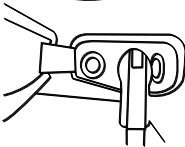
when closing, also press the right edge of the charging port cover, you can hear a slight "click" "sound, make sure the charging port cover is closed.

Charging methods	Charging port	Charging plug	Power supply interface	
Slow charge				Standard charging pile
				Household power supply
Fast charge				Fast charging pile

- 1
- 2
- 3
- 4
- 5
- 6
- 7
- 8
- 9
- 10
- 11
- 12

Charging

Charging time

The charging time depends on battery SOC, power supply, ambient temperature and battery's durable years. The charging time in this manual is only a nominal value, which may differ from actual time.

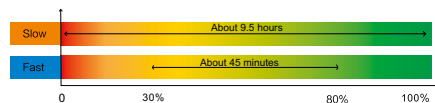

The car needs electric energy to be driven and the power battery is its only power source. When you are driving, the power of the battery is gradually reduced. A planned charge is very important to prevent the vehicle from driving due to the complete power battery loss.

Note:

- Judgment method of vehicle charging:
 - If the charging status indicator is lit while the vehicle is running, the power of the power battery is insufficient and it needs to be charged as soon as possible. When it is found that the power indicator on the meter is in the red zone, the power battery is running out of power and must be recharged as soon as possible.
- In order to extend the battery's lifespan and to ensure the driving safety, you should try to avoid vehicle's power in the red area.

Slow charge

In order to extend the lifespan of power battery, JAC recommends to use slow charge in daily charging to reduce the frequency to use fast charging function. Voltage and current of standard charger is 220V and 32A; for household power socket, the voltage is 220V, and the current is 16A.



Warning

- To avoid electrical shock or fire caused by a short circuit, please install a ground fault circuit interrupter in the circuit and use a waterproof earth socket.
- Incorrect use of charging equipment can cause fire or serious injury.
- Do not use aged charging equipment.
- Do not use the charging device if the output power outlet is damaged or not plugged in.
- If the charging or power outlet is abnormally hot or sending abnormal smells, stop charging immediately.
- Do not use charging equipment on the same circuit with other electrical appliances to ensure that the load of the power supply line can meet the needs of vehicle charging.
- Do not continue to use the faulty charger, please contact JAC authorized after-sales service store for a repair.
- There are no user-serviceable components in the charging device. Please do not attempt to repair the charging device without permission. The problems caused

by those are not covered by the warranty.

- The vehicle must be charged in a charging place with stable voltage. Power socket must be with electrical safety precautions, against water, moisture, dust, touch, leakage and others.
- The household power supply equipment used to charge the vehicle needs to be confirmed by a professional electrician who has a national vocational qualification certificate.
- It is forbidden to pull on any form of power cable, and you should prevent the power cable from being exposed. Otherwise, it may cause a fire.
- Do not squeeze the charging cable when charging, to avoid electric shock or fire.
- Do not use the damaged charging cable to charge.
- Do not modify the charging cable; If you need to lengthen the charging cable, JAC authorized after-sales service store can provide 10m or 20m dedicated charging cable for you to purchase.

▲ Attention: It is recommended to use charging equipment that complies with the national standard when charging, otherwise it may affect the normal battery charging.

Note:

- Before charging, please power off the vehicle; when the vehicle is in the READY state, it can not be charged.

Slow charge operation process

The following two methods can be used to charge the vehicle:

1. Standard charging pile

(1) Park the vehicle at a suitable distance from the standard charging pile. Please power off the vehicle, open the slow charging port cover and the charging socket protective cover.

(2) Remove the charging pile charging cable from the trunk, the end of the charging plug is marked "vehicle plug", and the other end is marked "power plug".

1

2

3

4

5

6

7

8

9

10

11

12

Charging

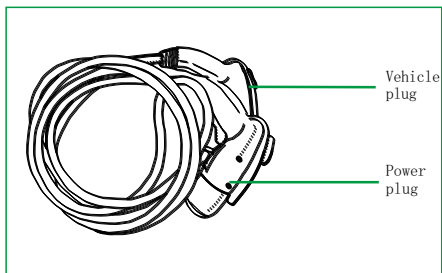

(3) Press the "power plug" yellow button, insert into the charging pile charging socket, and release the button.

(4) Press the "vehicle plug" yellow button, insert into the vehicle slow charging port charging socket, and release the button.

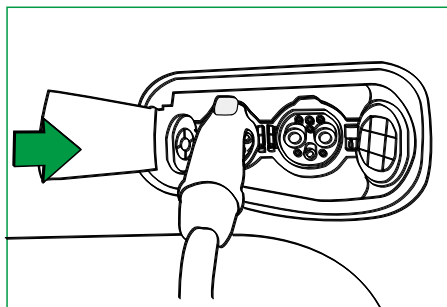

(5) Charge the vehicle according to the charging pile tips.

(6) When charging cable is connected, the vehicle charging indicator is yellow; then charging indicator turns green and normal mode charging starts. To view the remaining charge time, please power on the vehicle, then it can be displayed on the instrument.

(7) After power battery is full, the charging indicator flashes off.

(8) When charging is completed or it needs to suspend charging, first stop charging process in the charging pile by card application, charging indicator will go out, then press the key unlock button, the charging plug of vehicle will be unlocked, press the yellow button, unplug the charging plug, and then pull out the charging pile plug.

(9) Cover the vehicle charging socket protective cover, and close the charging cover.

(10) Tidy up the charging cable and put it in the proper place in the trunk.

2. Using household power supply (220V, 16A and above specifications socket) charging

(1) Park the vehicle at a suitable distance from the household power source. Please power off the vehicle, open the charging port cover and charging socket cover. Remove the household power charging cable and insert the power plug into the power supply socket.

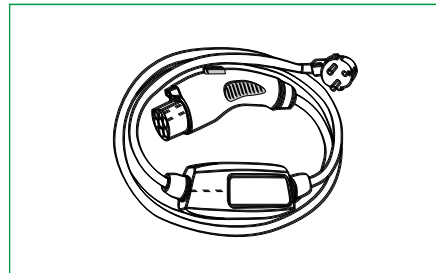



(2) Press the "vehicle plug" yellow button, insert into the vehicle charging socket, and release the button.

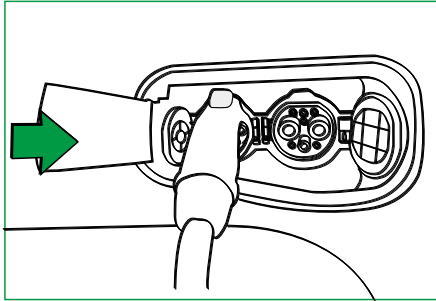

(3) When charging cable is connected, the vehicle charging indicator is yellow; then charging indicator turns green and normal mode charging starts. To check the remaining charging time, please power on the vehicle, then it can be displayed on the instrument.

(4) After power battery is full, the charging indicator flashes off.

(5) When charging is completed or it needs to suspend charging, press the

key unlock button, the charging plug of vehicle will be unlocked, press the yellow button, unplug the charging plug, and then pull out the charging pile plug.

(6) Cover the vehicle charging socket protective cover, and close the charging cover.

(7) Tidy up the charging cable and put it in the proper place in the trunk.

3. Charge with smart charging box

(1) Park the vehicle at a suitable distance from the smart charging box. Please power off the vehicle, open the charging port cover and the charging socket protective cover.

(2) Press the charging plug button on the smart charging box to remove the charging plug from the smart charging box.

(3) Press the lock button on the charging plug, insert the slow charging socket of the vehicle charging port, release the button.

(4) When the charging cable is connected, the vehicle charging indicator is yellow; then the charging indicator turns to green

and normal mode charging starts. To view the remaining charge time, please power on the vehicle, then the remaining charging time can be displayed on the instrument.

(5) When the battery is fully charged, the charging indicator flashes green and then goes out.

(6) When charging is completed or it needs to suspend charging, press unlock the button on the key, and the charging plug at the end of the vehicle is unlocked. Press and hold the button to pull out the charging plug.

(7) Cover the vehicle charging socket protective cover, and close the charging cover.

Tidy up the charging cable and insert it into the smart charging box.

1

2

3

4

5

6

7

8

9

10

11

12

Mechanical unlock device

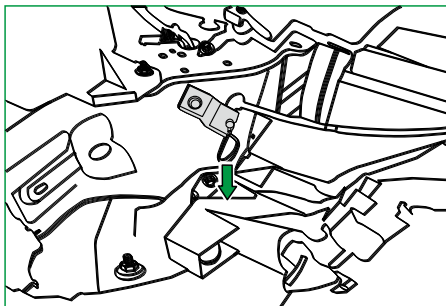

If slow charge socket mechanical lock is damaged, it will cause the lock of charging plug. Open the front hood, use a hard lever to pull the mechanical lock at the end of the slow charging socket outward until you hear the click sound and the socket is unlocked. If it appears any abnormal, please contact JAC authorized after-sales service store immediately.

Note:

- After the charging cable is connected, the vehicle will emit a "beep" sound, the charging indicator will turn yellow, and the charging cable is connected normally; Then the "beep-beep" sound will be heard twice, the charging indicator will change from yellow to green, charging begins. If the charging indicator is not bright or only yellow, it indicates that the vehicle did not enter the charging state. In this case, you should check whether the charging cable connection is reliable. If necessary, please contact JAC authorized after-sales service store immediately.
- Green charging indicator flashes and goes out, indicating that the power battery is fully charged.
- Before unplugging the charging cable, use the smart key, press the unlock button, the charging plug can be pulled out after being unlocked.

⚠ Attention: To increase battery's lifespan and safety, we recommend that you should:

- Charge immediately after parking and avoid charging when the energy is used out.
- Charge under ambient temperature between 0-35 °C.
- When the temperature is below zero, in order to shorten the charging time, please charge immediately after parking.
- When vehicle is placed for a long time (more than 1 month), please ensure that the power battery's SOC is between 50% -60%, and the 12V lead-acid battery negative is disconnected.



Fast charge

The vehicle should be equipped with a fast charge interface for fast charging by yourself.

It is recommended by JAC not to use fast charge more than once a week.

Please charge on fast charger which meets IEC 62196-3 standard. It is forbidden to charge on the non-standard fast charge pile.

Depending on where you live or where you travel, there may not be enough fast charging piles to meet your specific needs, so travel plans are important and you must plan your trip carefully.

Fast charge time depends on many factors, including the battery temperature and the type of fast charging pile. Charging time increases in cold regions (e.g., below 0 °C).

Warning

- Please use the fast charging device which meets IEC 62196-3 standard, or it may lead to malfunction or fire, resulting in serious injury or death.
- Please read carefully the operating instructions on the charging device before fast charging, to ensure that the quick charging plug is connected and locked, otherwise it will cause the malfunction of vehicle or charging equipment.
- Children are not allowed to charge the vehicle.
- Do not insert or detach the fast charge plug during charging.
- Charging or stop charging must be in strict accordance with the fast charging process of charging pile.
- If there is smoke on the charging interface, abnormal odor or abnormal phenomena inside the vehicle, press the emergency stop button on the charging pile in time to stop charging and evacuate the personnel around the vehicle and dispose of it according to the relevant procedures on the site.

⚠ Attention: As the fast charge plug is heavy, please insert and plug it vertically with caution as much as possible to prevent damage to the vehicle or charging equipment.

Note:

- During fast charging, accidental touching the fast charge plug button may stop charging and it needs to unplug the charging plug to recharge.

1

2

3

4

5

6

7

8

9

10

11

12

Charging

Fast charge operation process

(1) Park the vehicle at a suitable distance from the standard charging pile. Power off the vehicle.

(2) Open the charging port cover and fast charging socket protective cover, and confirm fast charge outlet is clean, dry and normal.

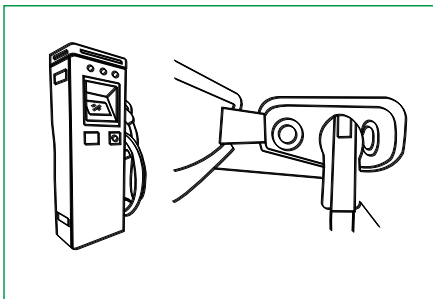

(3) Remove the fast charge plug from the fast charging pile, press the button, then slowly and vertically insert into the vehicle fast charge outlet, and then release the button.

(4) Charge the vehicle according to the charging pile tips.

(5) When charging cable is connected, the vehicle charging indicator is yellow; then charging indicator turns green and normal mode charging starts. To view the remaining charge time, please power on the vehicle, then it can be displayed on the instrument.

(6) Tidy up the charging plug, close the fast charge outlet cover and charging port. After power battery is full, the charging indicator flashes off. After confirming that there is no output current in the fast charging pile, hold down the plug button and slowly pull out the fast charging plug.

Warning

- Before fast charging, please check if there are debris, dust, water, etc. inside the fast charging socket (including the jack). If there is any abnormal, please do not charge. Please remove the debris, dust and water inside the fast charging socket (including the jack). Keep the charging socket clean and dry before continuing to charge.
- Before fast charging, please check whether the fast charging socket jack is damaged, ablated, or the jack color turns yellow (normal color is silver white). If any of the above happens, please contact JAC authorized after-sales service store immediately.



Charge indicator

Charging indicator is assembled on instrument panel's central part, which is on front windscreen's bottom side, indicating different statuses of charging.

Serial No.	Indicator status	Function
1	Yellow light	Charging cable is in connection
2	Green light	In charging
3	Green light blinks for 1 minute	Full charging
4	Extinguished	Charging is completed/uncharged
5	Yellow light blinks	Power battery automatically charges the 12V lead-acid battery

Charge at low temperature

Power battery heating device

As the capacity of power battery can be reduced when being charged or discharged in low temperature environment, the battery in this vehicle has a heating device, which can ensure that the battery has a suitable temperature under low temperature environment.

Warning

- The heating device is turned on automatically when the battery is charged and the temperature of the power battery is lower than a certain value.
- Charging time will be extended when heating device starts;
- In cold conditions, in order to ensure the driving range of the vehicle, you can choose the winter warm-up function before traveling. However, this function consumes electricity and it is recommended to use it when the charging cable is connected.

Note:

- When the vehicle is charged in low temperature environment (such as 0 °C), the charging time will increase.
- When the vehicle is driving in low temperature environment (such as 0 °C), the vehicle's power performance and driving range will decline.
- When the battery power is low (such as 10%), the power performance and driving range of the vehicle will decrease.
- When power battery is fully charged, in order to prevent overcharge, energy recovery will be automatically reduced. When the temperature of the power battery is too high or too low, energy recovery is also automatically reduced in order to prevent damage to the battery.

1

2

3

4

5

6

7

8

9

10

11

12

Charging troubleshooting guide

Symptom	Possible reasons	Possible solutions
Charging can not be achieved.	Vehicle is not powered off	Press the power switch to power off.
	Power battery is full	When the power battery is full, it can not continue charging; when the power battery is full, charging will stop
	Power battery temperature is too high or too low	Confirm the power battery temperature. If the LCD screen shows the battery temperature is too high or too low, it is not allowed to charge. The power battery cannot be charged until the temperature reaches the appropriate range. See "Chapter V Instrument and control" for details to check the temperature of power battery
	12V low voltage power supply is abnormal	If 12V low voltage power supply is abnormal (such as undervoltage or overvoltage), it can not be charged
	Vehicles or charging piles may be faulty	Confirm whether the system fault light on the instrument is lit; if lit, please stop charging and contact JAC authorized after-sales service store to confirm whether there is a fault in charging pile
Slow charge failure	Charging pile or household power is off	Check for power supply failure. Check if the outlet breaker is off
	Household power charging plug is not connected properly	Make sure the charging plug is correctly plugged into the socket of the household power supply
	The charging plug is not connected properly	Confirm whether charging plug is connected correctly



Symptom	Possible reasons	Possible solutions
Slow charge interruption	No power supply	Check for power supply failure. Check if the outlet breaker is off
	Charging cable connection is interrupted	Confirm whether charging cable connection is interrupted
	Power battery temperature is too high or too low	Confirm the power battery temperature. If the LCD screen shows the battery temperature is too high or too low, it is not allowed to charge. The power battery cannot be charged until the temperature reaches the appropriate range. See "Chapter V Instrument and control" for details to check the temperature of power battery. And please contact JAC authorized after-sales service store immediately.
Fast charge failure	Fast charge plug connection is not correct, or not fully inserted, or charging plug mechanical lock is not locked	Check the charging plug is connected properly, and confirm the charging plug mechanical lock is properly locked
	No power supply	Check for power supply failure
Fast charge interruption	Power supply interruption	Check whether the fast charge charging pile power is interrupted
	Press the charging plug button	Re-plug and re-insert the charging plug
	Power battery temperature is too high or too low	Confirm the power battery temperature. If the LCD screen shows the battery temperature is too high or too low, it is not allowed to charge. The power battery cannot be charged until the temperature reaches the appropriate range. See "Chapter V Instrument and control" for details to check the temperature of power battery. And please contact JAC authorized after-sales service store immediately.
Failure to pull out the vehicle's slow charge plug	Locked	Press the smart key unlock button
	Slow charge plug electronic lock failure	Open the front hood, pull up the electronic lock emergency opening drawing in the charging port

1

2

3

4

5

6

7

8

9

10

11

12





4

Safety devices--Seats and safety belts

- **Seat and adjustment** 42
 - Front manual seats..... 42
 - Electric adjustment for driver's seat* 43
 - Front seat heating 44
 - Rear seats..... 44
 - Child seat fixing..... 45
 - Child seat's applicability 46
- **Seat belt** 48
 - Why seat belt can protect us 48
 - Correct sitting posture 50
 - Three-point seat belts on front seats 52
 - Three-point seat belts on rear seats 53
 - Three-point seat belt on middle rear seat 54
 - Seat belt pretension device* 54
- **Protection for pregnant women and children** 55
 - Protection device for pregnant women and children .. 55
 - Protection for older children 56
 - Protection for the wounded 56
 - Protection for pregnant women 56
- **Children protection system (user-supplied)** 57
 - Vehicle children protection device 57
- **Airbag** 60
 - Front airbag 60
 - Side airbag* 62
 - Curtain-type airbag* 62
 - SRS parts and function..... 63
 - How SRS works 64
 - SRS maintenance..... 66

Seat and adjustment

Front manual seats

Seat's back & forth adjustment



Pull up and hold the joystick under the front of the seat to unlock the seat. Slide the seat to your desired position to release the joystick. Please try to move the seat back and forth to confirm that the seat is locked in place.

▲ Attention: Do not adjust the seat back and forth in driving, and deceleration or acceleration may cause the loss of control of the adjustment.

Seat backrest's angle adjustment

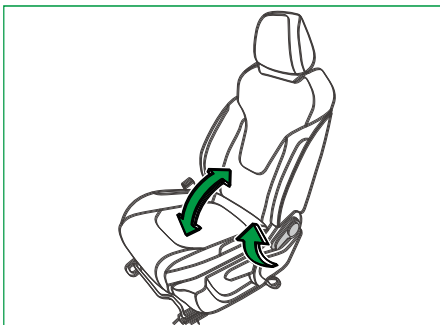

Your vehicle is equipped with a manual handle of seat backrest angle located on the outside of the seat.

Steps to adjust the seat backrest angle:

1. Lift up the adjustment handle and adjust the backrest to the desired position.
2. Unlock the handle and push back the seat backrest to make sure the backrest is locked.

▲ Attention: Pull up the handle and the seat backrest will move to vertical position.

Seat's height adjustment

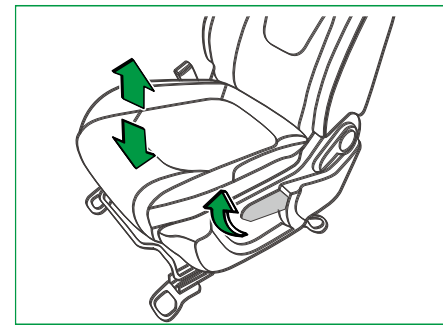

The driver's seat has a height adjustment handle, which is located outside the seat. Steps for seat's height adjustment: Move the height adjustment handle up or down and adjust the seat height to the desired position.

▲ Attention: When vehicle is running, adjusting the driver's seat may cause the vehicle out of control. Sudden movement of the seat may cause you to be scared or overwhelmed or cause you to step on a pedal unconsciously. The driver's seat can be adjusted only when the vehicle is stationary.



Seat headrest adjustment

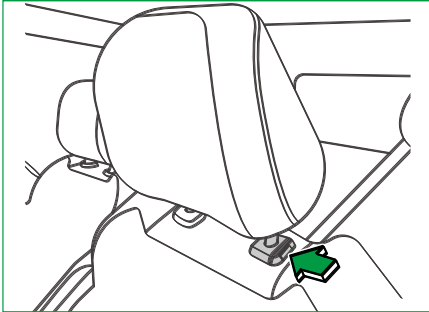

Adjust the height of the headrest so that its top is as close as possible to the top of your head. This position will reduce the chance of neck injury during a collision.
 Up: Pull up the headrest to raise it.
 Down: While pressing the headrest adjusting button, press the headrest down. To remove the headrest, pull the headrest upward to the uppermost position, and then press the release button to lift up the headrest from the guide sleeve.

⚠ Attention: Reinstall the headrest and adjust it to the proper position before driving.

Electric adjustment for driver's seat* Seat's back & forth adjustment

The driver's seat can be adjusted in different directions with the switch which is located on the left of the seat.

⚠ Attention: - When vehicle is running, adjusting the driver's seat may cause the vehicle out of control. Sudden movement of the seat may cause you to be scared or overwhelmed or cause you to step on a pedal unconsciously. The driver's seat can be adjusted only when the vehicle is stationary.

- Do not operate the seat in multiple ways at the same time, and it can only be operated in one way at one time.
- When the battery power of the vehicle is too low, the electric adjustment of the seat will be affected.

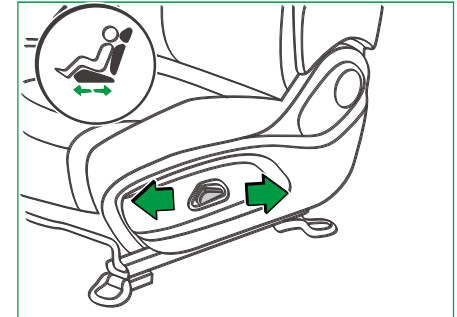

Push the switch along the arrow direction, and the seat can move forward and backward.

1

2

3

4

5

6

7

8

9

10

11

12

Seat's height adjustment

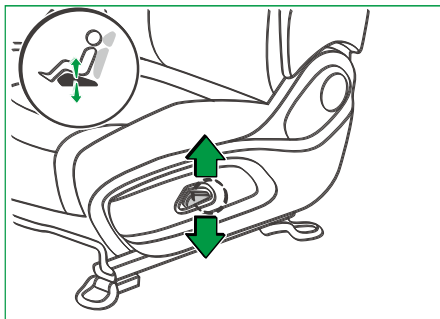

Press the switch along the arrow direction, and the height of the seat will decrease or increase.

Front seat heating

Slide the driver and co-driver seat heating button in MP5 vehicle settings to the right to turn on or off the seat heating function.

Rear seats

The seat backrest is split by four and six with forward folding function, and the operation button is located at the top of the seat backrest.

Seat backrest folding

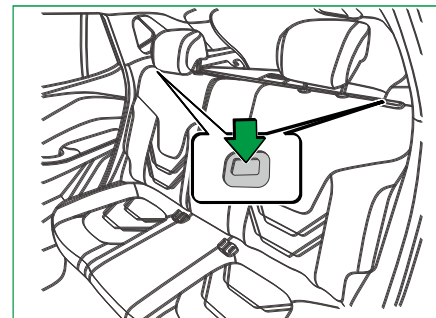

There is an unlock button on the backrest, and the backrest can be unlocked by pressing down the button and it can be folded forward after being unlocked.

⚠ Attention: Before unlocking the backrest, you should lower the headrest to the lowest position.



Seat headrest adjustment

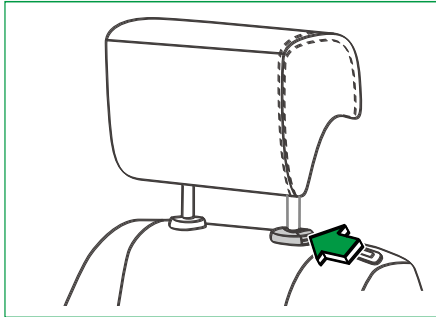

Adjust the height of the headrest so that its top is as close as possible to the top of your head. This position will reduce the chance of neck injury during a collision.

Up: Pull up the headrest to raise it.

Down: Press the headrest down while pressing the lock release button.

To remove the headrest, pull the headrest upward to the uppermost position, and then press the adjust button, and finally lift up the headrest from the guide sleeve.

Reinstall the headrest and adjust it to the proper position before driving.

Child seat fixing

Your rear row seats are equipped with ISOFIX standard interfaces on both sides for fixing two child seats. Please select the appropriate child seat according to the child's age and body shape.

Steps for installing child seats:

1. Move the front seat to the forefront.

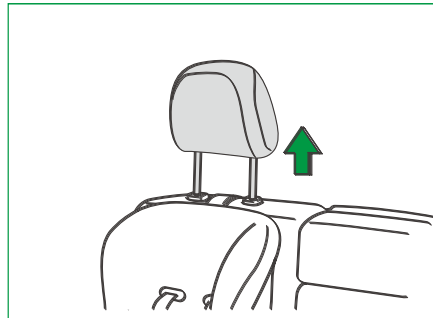

2. Raise or take off the headrest from the seat with a child seat.

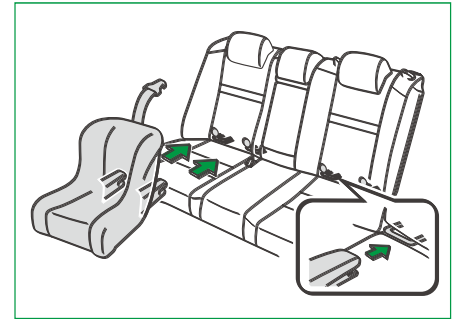

1

2

3

4

5

6

7

8

9

10

11

12

Safety devices

3. Slide the child seat lock mechanism into the lower fixed point to ensure that the two ISOFIX lock mechanisms are fixed correctly.

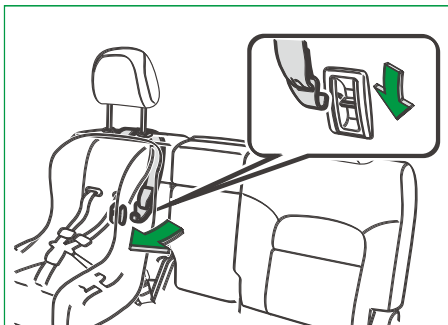

4. Fasten the pull-up belt to the corresponding fixed point and be careful not to crimp the pull-up belt. When fixing, make sure that pull-up belt passes under the seat headrest.
5. Shake the child seat gently to make sure it is firmly fixed.

▲ Attention: Do not install the child protection system on front passenger's seat. Because the airbag on the front passenger's seat will unfold in the event of an accident, resulting in serious injury or death of child on the child seat. Therefore, the child restraint system should only be installed on the rear seat of the vehicle. After installation, try to move in all directions to check whether the child restraint system is securely installed.

Child seat's applicability

The applicability information of different seats to the child restraint system.

Quality group	Occupancy position		
	Front passenger's seat	Rear outside seat	Rear middle seat
Group 0: <10kg	X	U/L	X
Group 0+: <13kg	X	U/L	X
Group I: 9kg~18kg	X	UF/L	X
Group II: 15kg~25kg	X	UF/L	X
Group III: 22kg~36kg	X	UF/L	X

Note: the meanings of the letters in the table are:

U=Applicable to the universal child restraint system with the approval of this quality group.

UF=Applicable to the universal forward child restraint system with the approval of this quality group.

L=Applicable to the special child restraint



- 1
- 2
- 3
- 4
- 5
- 6
- 7
- 8
- 9
- 10
- 11
- 12

system on the list. These may be special vehicles , limited or semi-universal restraint systems.

B=Applicable to the built-in child restraint system with the approval of this quality group.

X=Not applicable to the child restraint system of this quality group.

The table shows the applicability information of different ISOFIX positions to the child restraint system.

Quality group	Fixing device	ISOFIX		
		Front passenger's seat	Rear outside seat	Rear middle seat
/	Fi-size	X	X	X
Portable	ISO/L1	X	X	X
	ISO/L2	X	X	X
Group 0: < 10kg	ISO/R1	X	IL	X
Group 0+: < 13kg	ISO/R1	X	IL	X
	ISO/R2	X	IL	X
	2SO/R2X	X	X	X

Quality group	Fixing device	ISOFIX		
		Front passenger's seat	Rear outside seat	Rear middle seat
	ISO/R3	X	IL	X
Group I: 9kg~18kg	ISO/R2	X	IL	X
	ISO/R3	X	IL	X
	ISO/F2	X	IUF	X
	ISO/F2X	X	IUF	X
	ISO/F3	X	IUF	X
Group II: 15kg~25kg	(1)	X	X	X
Group III: 22kg~36kg	(1)	X	X	X

Note: the meanings of the letters in the form are:

IUF=Applicable to the universal forward child restraint system with the approval of this quality group.

IL=Applicable to the special child restraint system on the list. These may be special vehicles , limited or semi-universal restraint systems.

X=Not applicable to the child restraint system of this quality group or this size category.

Seat belt

The seat belt device is a connector fixed inside the vehicle, and an assembly which is used for reducing the injury by limiting the movement of the wearer's body in the event of a sudden deceleration or collision. In order to protect drivers and passengers from injuries in traffic accidents, the driver and passengers must always fasten their seat belts.

Proper wear of seat belts and proper use of seat belts can reduce the damage caused by accidents or emergency braking, and reduce the likelihood of serious injury or death.

Warning

- One seat belt is for one person only. It is forbidden for two persons (children included) to share a seat belt, otherwise serious injuries will occur in an accident.

Why seat belt can protect us

When you sit inside or above an object, you move at the same speed as that object.

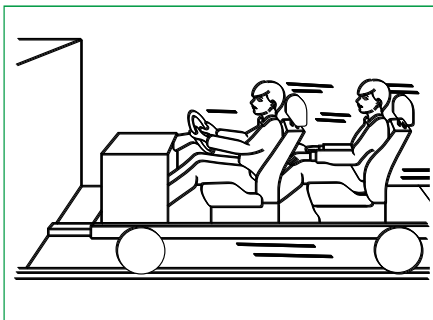

Take the simplest vehicle for example, assuming that the vehicle is a seat with wheels on it. Let people sit on it. Accelerate it, then stop it, the person on it will not be stopped.

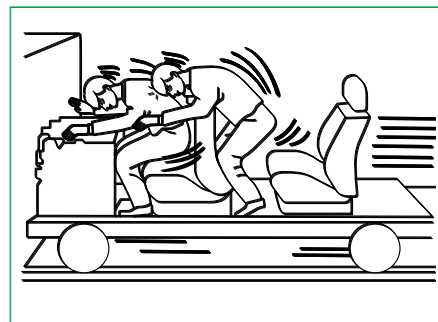

This person keeps moving forward until he is blocked by an object. On the actual vehicle, the object may be a windscreen or a dashboard or a seat belt.

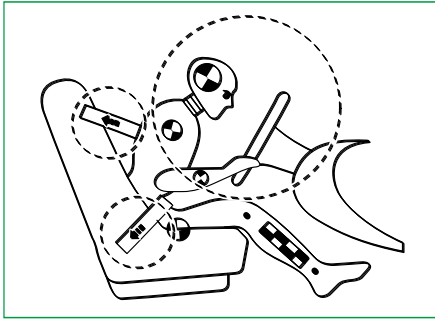

After fastening your seat belt, you will slow down with the vehicle. You have more time and more distance to stop moving, and you will be forced by the strongest bones in your body. This is why seat belts are so important.

Protection of seat belts

The seat belt system cannot be broken down or modified. Ensure the quality of seat belts and other hardware of seat belts to ensure they are not abused or damaged by door or seat hinges.

It is forbidden that foreign objects fall into the buckles of the seat belts. If any foreign object falls into the buckle, it cannot be normally locked or unlocked. If the function is abnormal due to shells or other foreign objects falling into the buckle, please go to JAC authorized after-sales service store for replacement as soon as possible.

▲ Attention: When you pull the back of the rear seat to the upright position after it is folded, be careful not to damage the sling or buckle of the seat belt, and make sure that the sling or buckle is not clamped or stuck by the rear seat.

Inspect the seat belt regularly

Inspect all seat belts for wear or other damage regularly. If the parts of seat belt system are damaged, replace them as soon as possible.

Keep the seat belt clean and dry

The seat belt should be kept clean and dry. If the seat belt is dirty, clean it with mild soap solution or warm water. Do not use bleach, dye, strong detergent or abrasive, as those will damage or weaken the fabric of the seat belt.

When to replace the seat belt

If there is a traffic accident., replace the entire seat belt assembly and components. Replace them even if no damage is found. For the operation of the seat belt, please consult JAC authorized after-sales service store.

1

2

3

4

5

6

7

8

9

10

11

12

Correct sitting posture

Significance of correct sitting posture

Correct sitting posture is crucial for the best protection of seat belts and airbags. The driver's and the front passenger's seats can be adjusted in many directions according to the occupant's body condition.

Correct sitting posture can ensure:

1. Control the vehicle accurately, effectively and safely.
2. Support the body effectively to avoid driving fatigue.
3. Play the best protection role of seat belts and airbags.



In order to reduce the chance of injury in an accident and to maximize the protection of the protection system, all occupants of the vehicle must remain seated while in the front seat should be in an upright position. Lying in the rear seat or the front seat in a tilted position will cause the seat belt from functioning properly.

⚠ Attention: It is very dangerous to lie or sit in an inclined state while the vehicle is running. Even if you fasten the seat belt buckle when you tilt, the seat belt does not rely on your body and can not effectively protect you. The collision of the vehicle will lead you to jerk forward; powerful impact will cause serious injury to your neck or other parts. The crotch seat belt can not play the protective function either. In the event of a collision, the crotch belt may move up to your abdomen, and the seat belt's impact on your abdomen, rather than the hard pelvis, causes you to suffer serious internal injury. To ensure safety while driving, adjust the seat back to an upright position and use the seat belt correctly.



Correct sitting posture of the driver

Correct sitting posture is critical to safe driving. To ensure your safety and reduce danger, the driver is advised to make the following adjustments:

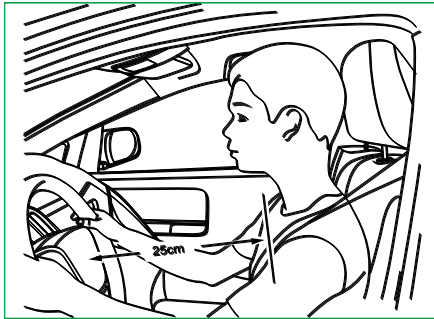

1. Adjust the steering wheel: The distance between the steering wheel and the chest should not be less than 25 cm.
2. Adjust the driver's seat back and forth: It is convenient for the driver to operate effectively on the acceleration and brake pedals.
3. Adjust the headrest: Headrest should be

- adjusted properly according to height.
4. The seat back should be upright and your back should be fully attached to the backrest.
 5. Wear the seat belt correctly.

Correct sitting posture of front passenger

To ensure your safety and reduce danger, the front passenger is advised to make the following adjustments:

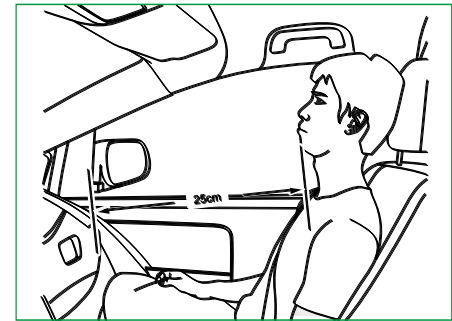

1. The distance between the front passenger and the dashboard should not be less than 25 cm.
2. The seat back should be upright and your back should be fully attached to the backrest.
3. Adjust the headrest to keep it in line with the head.
4. Wear the seat belt correctly.

1

2

3

4

5

6

7

8

9

10

11

12

Safety devices

Three-point seat belts on front seats

All seats in the vehicle are equipped with the three-point seat belts. The following instructions illustrate how to wear a three-point seat belt correctly.

Fasten three-point seat belts

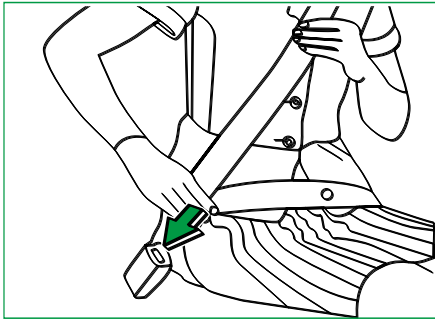

To fasten the seat belt, pull the belt out of the retractor and insert the spring bolt into the buckle until you hear a "click" sound that means the seat belt is locked well. Only after you have adjusted your seat belt with your hand, the belt can be automatically adjusted to the appropriate

length so that it can be better positioned around your hips. If you lean forward slowly without hindrance, the seat belt will stretch so you can move freely. If an emergency braking or impact happened, the seat belt will be locked.

Adjust three-point seat belts

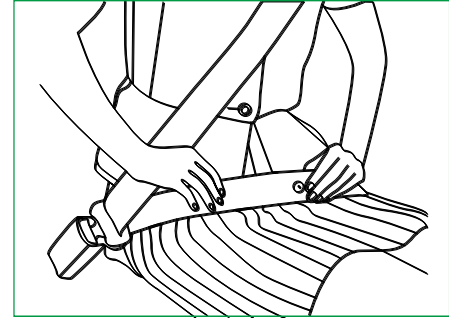

You should try to lower your seat belt to your hip, not your waist. If the seat belt is placed too high when an accident or emergency braking occurs, you may slip out of it and the risk of injury is increased. Do not put your hands on the same side of the seat belt, and the hands should be placed on both sides of the seat belt. Do not fasten your seat belt under your arm near the door.



Release three-point seat belts

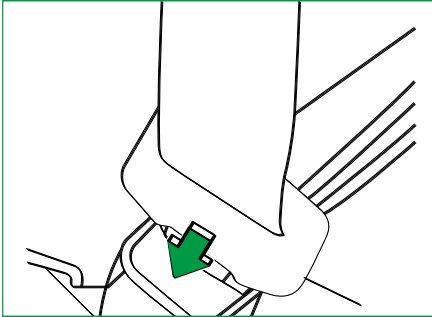

Press the release button in the buckle ring to release the seat belt. When the seat belt is being released, it will automatically retract the contraction box. Otherwise, check the seat belt for knots and try again.

Height adjustment of seat belt*

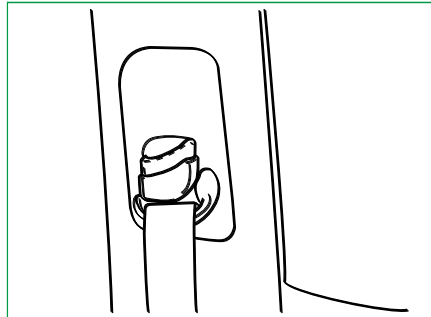

You can adjust the seat belts' height of the driver's seat and the front passenger's seat. The height of the seat belt can be adjusted by the fixed seat. Adjust the height of the seat belt so that its upper part goes around the middle of the shoulder.

If you need to increase the height of the fixed seat of seat belt, just push up the protruding bolt on the adjusting device; to lower the height of the fixed seat of seat belt, simply tap the protruding bolt on the adjusting device downward.

Three-point seat belts on rear seats

The rear seats on both sides in your vehicle are equipped with three-point seat belts; the methods of fastening, adjusting and releasing the rear seat belts are the same with the front.

▲ Attention: When the rear seat belt is being used, make sure to insert the spring bolt into the correct buckle.

1

2

3

4

5

6

7

8

9

10

11

12

Three-point seat belt on middle rear seat

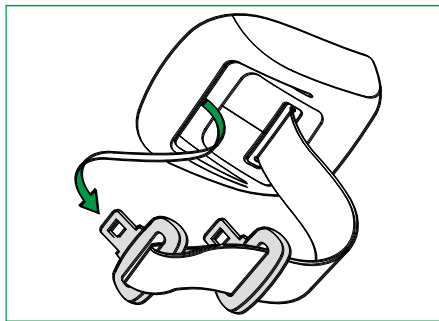

Three-point seat belt on middle rear seat is in the collected box in the roof of the vehicle.

Use of three-point seat belt on middle rear seat

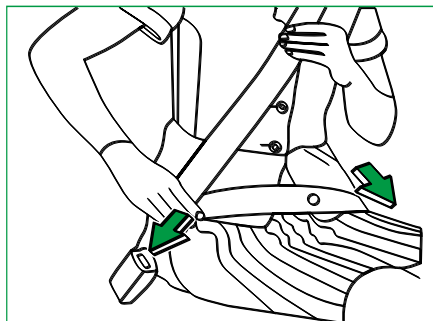

Insert the front-end spring bolt of three-point seat belt on middle rear seat into the left buckle and the middle spring bolt into the right buckle. When you hear a "click" sound, it means the seat belt is locked well. Press the release button in the buckle ring to release the seat belt.

Seat belt pretension device*

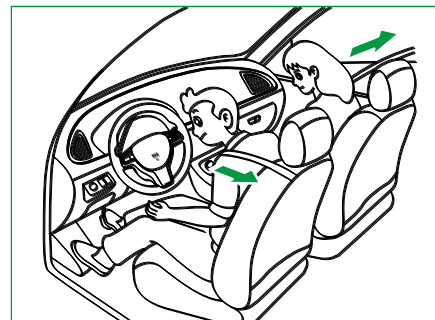

Some models are equipped with seat belt pretension devices for driver's and co-driver's seats. The purpose of installing this device is to ensure the safety of the driver and co-driver in the event of a certain degree of frontal impact.

The seat belt pretension device can work with the airbag at the same time. When the vehicle suddenly stops or when the occupant is rapidly tilted forward, the seat belt's retractor will be locked. In a certain degree of frontal impact, the seat belt



pretension device operates to tighten the members and cushion the forward force of the occupant.

▲ Attention: - Please change the seat belts in time after the pretension device has been used in collision.

- Working principle of seat belt pretension:
When the gunpowder in the gas generator is lit, air pressure is produced in the pipe, pushing the lead ball to move around the drive gear. The drive gear drives the spindle reversely, the ribbon is recycled, and the lead ball is collected by the tank .

Protection for pregnant women and children

Protection device for pregnant women and children

Protection for infants and young children

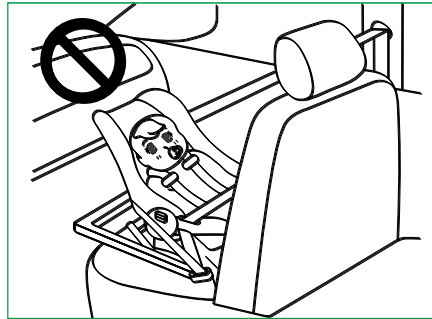

Some countries require infants and young children to use child protection systems. No matter it is required by a law or not, we strongly recommend that infants or children under 18kg be protected by an infant protection system or a child

protection seat.

Airbags are designed to protect adults when accidents occur, posing a significant risk to children. Do not install the child protection device on the co-driver's seat with an airbag. Otherwise when the airbag inflates, the huge impact may lead to infant's injury or even death.

When buying a particular child protection system for your child, it must be confirmed that the system is appropriate with your child, seats and seat belts, and the installation and use of child safety seats should be carried out in accordance with the seat manufacturer's instructions. This vehicle is equipped with ISO FIX international standard safety interface device for the installation of child seat. Proper use of child protection system protects children as much as possible in the event of an accident.

1

2

3

4

5

6

7

8

9

10

11

12

Safety devices

Protection for older children



Older child too big to use a child protection system should be placed in the rear seat and use a knee/shoulder seat belt. The knee seat belt should be worn around the hip and as low as possible. Check the assembly of the seat belts regularly.

The child may be squirming so much that his seat belt is out of position. If the child is properly protected by the backseat child protection system, the protection system can provide the safest protection for the child in case of incident.

If a older child (over 13 years old) must sit in the front seat, use a knee/shoulder seat belt and place the seat in the most rear position.

Children under 13 years old must sit in the back seat and be protected, and do not place children under 13 in the front seat. It is prohibited to place child protection system facing back in the front seat of vehicle.

Protection for the wounded

Use the seat belt when transferring the wounded. If necessary, consult your doctor about common sense.

Protection for pregnant women



Pregnant women should follow the doctor's special instructions about taking a car. Use a three-point seat belt whenever possible. The hip seat belt should be as comfortable as possible and as low as possible.

Pregnant women should also try to stay away from the steering wheel or dashboard, and sit close to the seat back to reduce the risk of injury to the mother and fetus caused by a collision or airbag inflation.



Warning

- NEVER use a rearward facing child restraint on a seat protected by an ACTIVE AIRBAG in front of it, DEATH or SERIOUS INJURY to the CHILD can occur.



Children protection system (user-supplied)

Vehicle children protection device

Children should be seated on the rear seat and properly activate protective device when riding in vehicles, which can reduce the risk of injury in emergency braking or sudden movement. According to the accident statistics, under the premise of correctly starting the protection device, children sitting in the back seat can be better protected than sitting in the front seat. Elder children who are not suitable for child protection system must wear safety belts.

A qualified child protection system must be used. Child protection system (safety seats) must be started when infants or children are in the vehicle. Failure to provide reliable protection for children could result in injury or death of children in the event of a collision. Infants must use qualified infants seats. When buying a specific child restraint system, be sure

to match it with your child, vehicle seat and seat belt. When installing the child protection system, please refer to the instructions provided by the manufacturer. When installing the child guard system on side rear seat, plug out the hip/shoulder safety belt from the retractor. Lock the safety belt and maintain it with a certain degree of tightness. Make sure the hip belt of the safety belt is fastened on child's face and neck. After installing the child restraint system, try to move in all directions to check whether the child protection system is securely installed or not.

1

2

3

4

5

6

7

8

9

10

11

12

Safety devices

▲ Attention: - Please install the child protection system on the rear seat. Do not install the baby seat on the co-driver's seat. Otherwise, when the accident happens, the passenger side airbag will cause serious injury or even death of infants in baby seats. Therefore, you must install the child protection system on the rear seat.

- The temperature of the enclosed car seat belt or child protection system can be very high. Therefore, the temperature of the seat surface and the lock must be checked before placing the children so as not to burn children.

- When child protection system is not used, put it into the luggage compartment to store it. Use a safety belt to bundle it tightly, in order to prevent being thrown out during emergency braking or an accident.

▲ Attention: - Elder children are not suitable for child restraint systems and they must use the knee/shoulder safety belt. Do not allow children to sit on the co-pilot seat.

- Do not use child safety seats or child protective devices that exceed the back of the seat, because it does not provide adequate safety protection during an accident.

- Never place a seat belt across the middle of a child's shoulder. Do not wrap it around the neck or back. Move the child closer to the seat belt lock so that he can get a better safety belt shoulder strap protection. A hip seat belt or intermediate seat belt must be kept as low as possible so that it is best fitted around the child's hip.

- When driving, it is forbidden for infants or children to stand or kneel on the seat.

- Do not hold children in the arms when driving, otherwise it will not provide any protection for children, but also seriously injures children when emergency braking or accident happens. It is the same even if

you hold the child with seatbelt fastened.

- If the child protection seat is not fixed in place, it will greatly increase the risk of serious injury or death in the collision.



Child seat interface

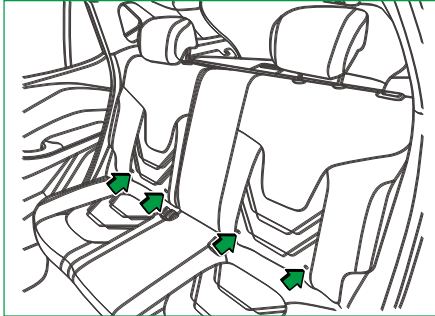

Your rear row seats are equipped with ISOFIX standard interfaces available for child seats each side. Please select the appropriate child seat according to the child's age and size.

Child seat installation steps:

1. Move the front row seat to the forefront.

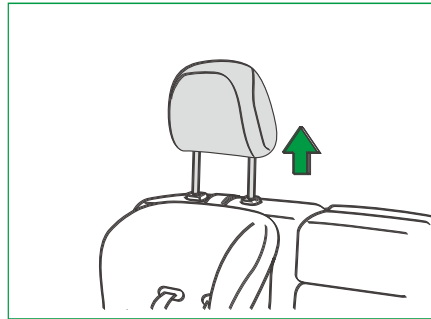

2. Raise or take off the headrest from the seat that the child seat installed.

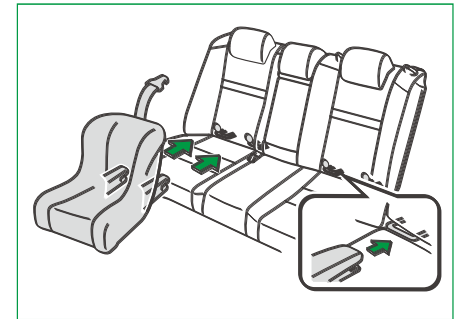

3. Slide the child seat lock mechanism to the lower fixing point, to make sure that two ISOFIX fixing mechanisms have fixed properly.

1

2

3

4

5

6

7

8

9

10

11

12

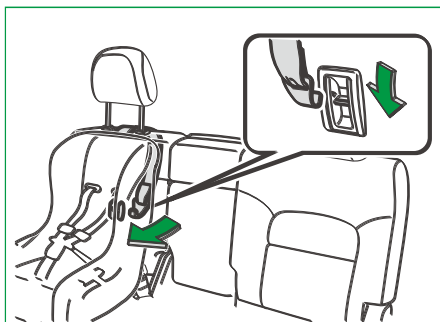

4. Fasten the upper puller strap to the corresponding upper puller strap fixing point, and pay attention to not curling the upper puller strap. When fixing, make sure that the upper puller strap is below the seat headrest.

5. Shake the child seat gently, and make sure that it has been fastened.

Before installing the child protection system, please read the instructions provided by the manufacturer.

If you cannot follow the instructions, please contact the JAC authorized after-sales service store immediately and check the system.

⚠ Attention: Do not install the child protection system on the passenger seat. Because when an accident occurs, the airbag on the front passenger seat will unfold, which may cause serious injury or death to children in the child seats. Therefore, the child restraint system should only be installed on the rear seat of the vehicle. After installation, try to move in all directions to check whether the child protection system is securely installed or not.

Please do not hang any other objects on ISOFIX rigid fixed anchors to avoid being damaged, which may cause life risk.

If the driver's seat prevents the proper installation of child protective device, install the child protective device on the right one of the second row seats.

Adjust the front passenger seat to avoid the block of child protective device.

Airbag Front airbag

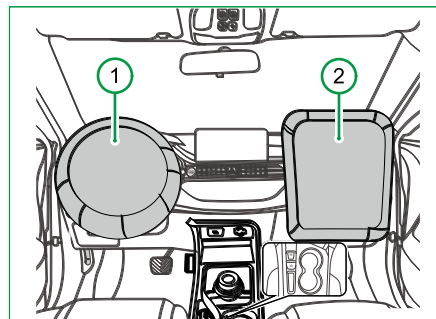

1. Front airbag on driver's seat
2. Front airbag on co-driver's seat

⚠ Warning

- Even if the vehicle is equipped with airbags, the driver and the occupant must wear the seat belt at all times to minimize the risk and severity of the collision or rollover accident.



▲ Attention: - The front airbag inflates with a large force, faster than the blink of an eye, and if you are too close to the inflatable airbag (for example, when you lean forward), you may be seriously injured. Before and during the crash, the seat belt will try to fix you in the seat so that the airbag can be inflated. Even your vehicle is equipped with airbags, you must wear a seat belt. In the premise of keeping vehicle in control, the driver should sit back as far as possible. The front passenger is prohibited from leaning or sleeping on the door.

- Do not hold or place anything on the steering wheel or any other airbag cover or near the airbag. Do not allow the seat cover to block the side airbag's inflation channel.
- When the airbag is being inflated, there will be dust in the air. The dust can cause respiratory problems for people with a history of asthma or other respiratory problems. To avoid this, everyone in the vehicle should get off safely as soon as possible.
- If you have a respiratory problem and cannot get off after the airbag is inflated, open the window or door to breathe the fresh air. If you

have respiratory problems after the airbag is inflated, seek medical attention.

- If you don't wear a seat belt (even if you have an airbag), a serious injury may be caused by an accident. Wearing a seat belt in a collision will help to reduce the likelihood of a collision between the passenger and the object in the vehicle. The airbags are designed to fit the seat belt rather than instead of the seat belt.

- The front airbags of the driver and co-pilot are designed for moderate, or even severe, frontal or near-frontal collision. These airbags are not designed for rolling over, rear collision, low-speed frontal collision or side collision. Furthermore, for passengers who do not wear seat belts, the damage may be greater in the event of a frontal collision.

All people in the vehicle should wear seat belts correctly, regardless of whether they are equipped with airbags.

- If you damage the airbag cover of the driver or co-driver, the airbag can not work normally. You may have to replace the airbag module on the steering wheel, the airbag module on the right front passenger, and the dashboard. Do not open or damage the airbag cover.

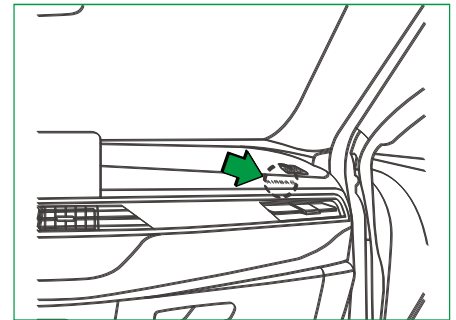
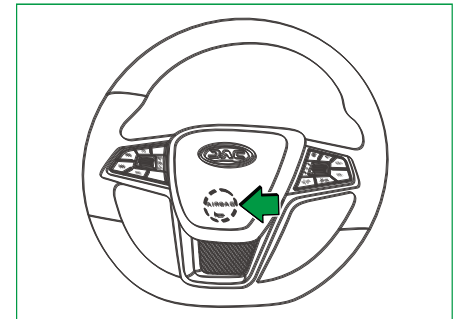

Your vehicle is equipped with a supplemental restraint system (SRS) bearing the words "AIRBAG" on the

1

2

3

4

5

6

7

8

9

10

11

12

steering wheel center horn cover and on the front dashboard of the front passenger seat. In collisions, in addition to the protection provided by the seat belts, the SRS provides additional protection for the driver and front passenger.

 **Attention:** Please read the SRS instructions provided on the co-driver's sun visor.

Warning

- The airbags are designed to fit the seat belt rather than replacing the seat belt. All people in the vehicle should wear seat belts correctly, regardless of whether they are equipped with airbags.
- The airbag will be inflated in the frontal collision, but it can not be opened on account of side collision, rear collision, or rolling over. The airbag can only be used once and cannot be reused.

Side airbag*

When the vehicle's side is subjected to enough intensity impact, the sensor will trigger the side airbag to inflate.

The side airbag is integrated in the seat back near the door, which mainly provides extra protection for the driver and front passenger. The protecting parts is the chest of front person and the hip when side collision happens.

Warning

- An inappropriate seat cover will block the trigger of airbag that is mounted on the back of the seat, causing the airbag to fail to perform the desired protective effect.

Curtain-type airbag*

When the vehicle's side is subjected to enough intensity impact, the sensor will trigger the curtain-type airbag to inflate. The curtain airbag can enhance the protection for head of the person who sits at the side where the crash occurs (it can not provide the protection for the chest and arm).

The curtain-type airbag is assembled on vehicle roof's side part, and provide extra protection for personnel on front and rear seats.

Warning

- Do not hang the heavy and hard things on the roof armrest and cloth hook.



SRS parts and function

The vehicle's supplemental restraint system (SRS) includes:

- Airbags (driver/co-driver)
- Seat belt pretension device
- SRS control components
- SRS airbag indicator

When the power switch is on the ON position, the SRS control components continuously monitor the impact from the front and decide whether the collision is serious enough to open the airbag or not. When the power switch is transferred to ON, the SRS airbag indicator on the dashboard will flash for 6 seconds before it goes out.

Note:

● If the airbag indicator does not go out after the vehicle is started or goes on during driving, it means the SRS is abnormal. Please immediately go to the nearby JAC authorized after-sales service store for inspection and maintenance.

When the SRS control components find that the front impact of the vehicle is large enough, they will control the airbag to expand automatically. Fully inflated airbags and proper seat belts can slow down the movement of the passenger and driver, relieving head injuries. The airbag will shrink after it expands, leaving the driver with a front vision.

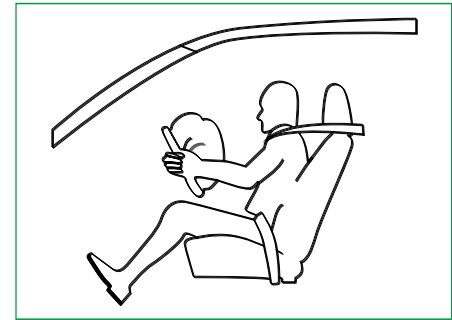

1

2

3

4

5

6

7

8

9

10

11

12

How SRS works

When there is a large enough frontal crash, the SRS will sense a sharp deceleration and immediately open the airbag and charge it quickly while starting the seat belt pretension device.

In collision, the seat belt assists in securing your lower body and torso; the airbag absorbs the energy of the impact and protects the head and chest.

The airbag deflates instantaneously after being inflated with an interval of about 0.1s. So that it will not block the driver's attention and prevent the manipulation of vehicle.

Detonation may occur during operation of the SRS and smoke can be seen. This is normal. The smoke is actually a powder on the surface of the airbag. Please wash your face and hands with warm water and soap later to avoid skin allergy.

Warning

- SRS can work only when the power switch is in ON. If the airbag indicator does not react when the power system is started or continuously goes on during driving, the SRS may have a fault, please go to the JAC authorized after-sales service store for inspection.
- Turn off the power switch before replacing the fuse or disconnecting the battery terminal. Do not remove or replace the fuse connected with the airbag when the power switch is in ON. Otherwise the indicator will be lit.

Situations that may trigger the airbag

1. The vehicle suffers severe collision in side-front direction which may cause severe injury to occupants.

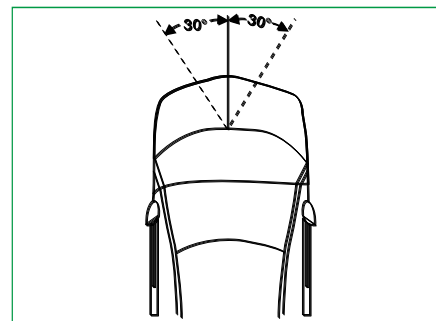

2. Frontal impact on the cement wall that cannot move or deform.

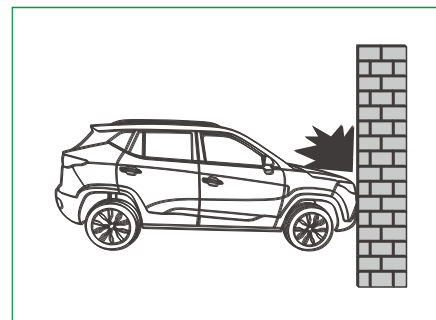



Situations that may not trigger the airbag

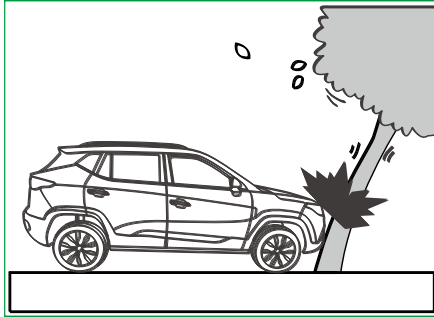

The vehicle collides with trees or other objects that are easily deformed.

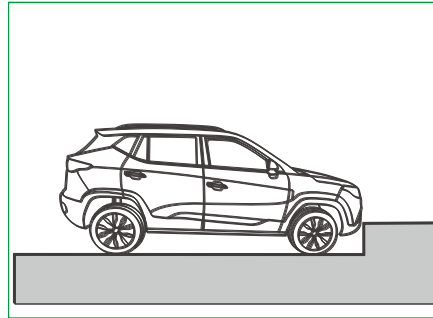

The vehicle collides with steps or other low objects.

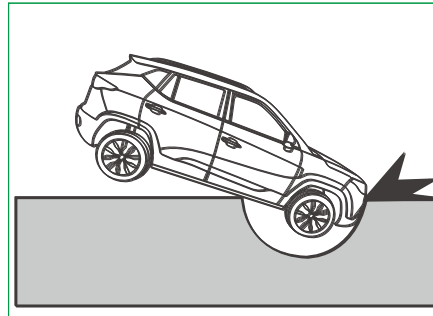

The vehicle falls into a deep pit or a deep ditch.

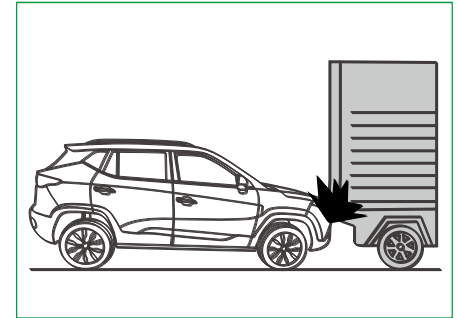

The vehicle suffers a rear-end collision with the truck.

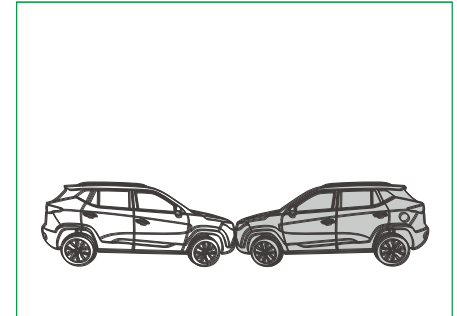

The vehicle suffers slight frontal collision.

- 1
- 2
- 3
- 4
- 5
- 6
- 7
- 8
- 9
- 10
- 11
- 12

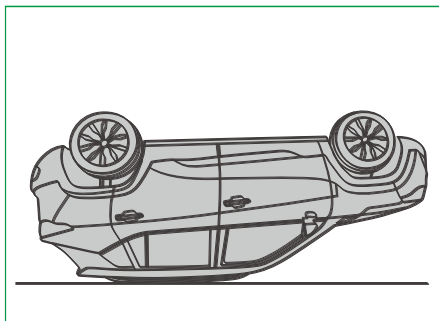

The vehicle suffers a turnover, side collision, rear collision, and a slight frontal collision; SRS failure or other special situations.

SRS maintenance

The SRS is a system that does not require maintenance in fact. Please go to the JAC authorized after-sales service store for a repair if any failure exists on SRS.

The dismantling, installation and maintenance of the SRS must be completed by JAC authorized after-sales service store and professionals. Improper repairs will cause serious safety problems. Wipe the place where the airbag is located with a clean cloth and clean water. Do not use chemical cleaners with unknown ingredients.

Warning

- Do not change the facility or circuit layout of the SRS as it may cause the system to lose functionality and not be triggered when a collision occurs.
- Do not mess with the airbag or SRS components and their circuit layout, as it may cause abnormal airbag inflation and injury to you or related personnel.



5

Instrument and control

- Combination instrument overview 69
- Combination instrument 70
 - Power battery power meter 70
 - Power battery available capacity table 70
 - Power battery thermometer 70
 - Power meter 70
 - Speedometer 70
 - Total mileage 70
 - The subtotal mileage 71
- Indicator and warning light 72
 - Check indicator/warning light 74
 - Indicator 74
 - Warning light 76
- Voice reminder 78
- Combination switch 79
 - Turn lamp switch 79
 - Headlamp switch 79
 - High beam lamp switch 80
 - Headlamp flash 80
 - Fog lamp switch 80
 - AUTO lighting 81
 - Front windshield wiper 81
 - Rear windshield wiper 82
 - Windshield washer 82
- Multi-functional steering wheel 83
 - Left buttons 83
 - Right buttons 84
- Left lower switch group 85

Instrument and Control

● Hazard warning flash light switch.....	85	Rear fog lamp and retro-reflector	90
● Interior illumination	86	High brake lamp	91
Front roof lamp.....	86	Position lighting	91
Rear roof lamp.....	86	Follow me home.....	91
Logo lamp.....	86	Power saving function	91
● Vehicle lamps	87	● Anti-theft system.....	92
Electric adjustment of headlamp	88		
Turn lamp	89		
Rear combination lamp	89		



Combination instrument overview

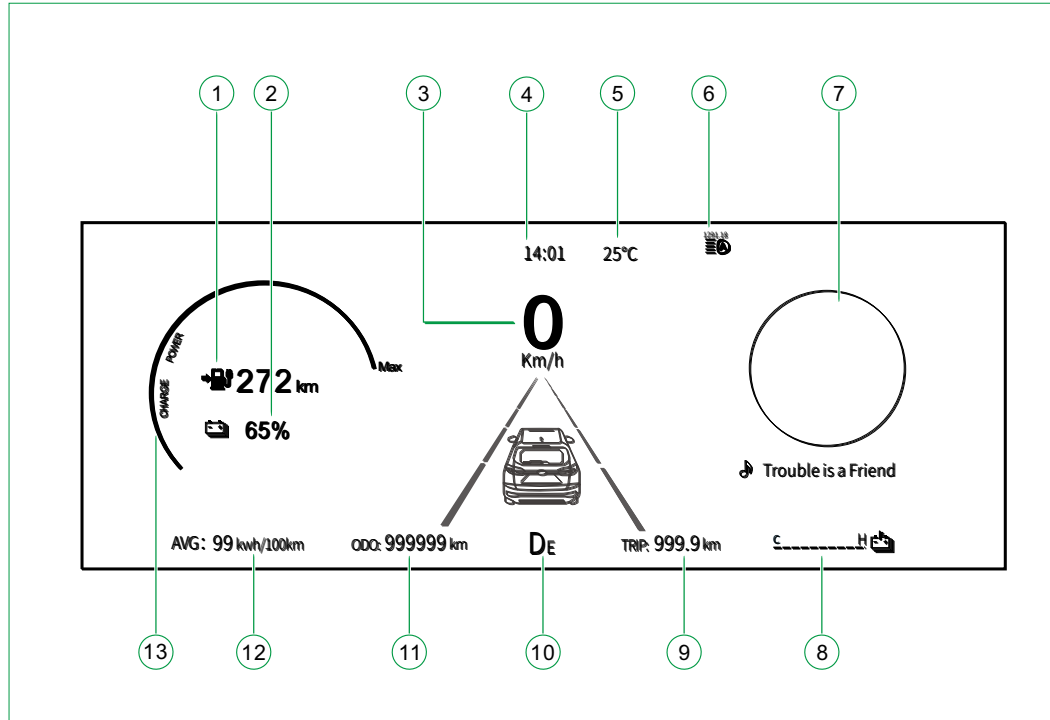

1. Endurance mileage
2. Power battery power meter
3. Speedometer
4. Time
5. Temperature
6. Indicator light
7. Menu, sub-function
8. Power battery thermometer
9. The subtotal mileage
10. Gears
11. Total mileage
12. Average power
13. Power meter

1

2

3

4

5

6

7

8

9

10

11

12

Combination instrument

Power battery power meter

Indicates the power battery power, that is, the SOC value. When the power battery power (SOC) is lower than 15%, the percentage value will flash to remind that the remaining power is limited, and it is recommended to charge as soon as possible.

Power battery available capacity table

Indicates the current available capacity of the power battery, and the available capacity of the battery decreases with the increase of the charge and discharge times and the use time of the battery.

Power battery thermometer

Indicates the current temperature level of the power battery. The temperature of the power battery changes according to the current outdoor temperature and driving conditions. When the temperature of the power battery is too high or too low, it will affect the vehicle's driving and braking energy recovery performance.

Power meter

The power meter indicates the current motor drive (POWER) power and brake energy recovery (CHARGE) power status.

Speedometer

Display the current vehicle speed by km / h (km per hour).

Total mileage

The total mileage is shown as the total mileage of the vehicle, with a minimum resolution of 1 km. The odometer is displayed by 6 digits, the zero before significant digits will not be displayed. The range of the total mileage is from 0km to 999999km. When the maximum is reached, the value will not be reset and re-calculated to maintain the maximum effective value.



The subtotal mileage

Subtotal mileage shows the mileage of the vehicle since the last reset with a minimum resolution of 0.1 km. The odometer is displayed by 5 digits, the zero before significant digits will not be displayed. The range of the subtotal mileage is from 0km to 999.9km. When the maximum is reached, the subtotal mileage is displayed as 0 km and recalculation begins. The subtotal mileage can be reset through the reset function of driving information under the vehicle setting option. The instrument has the function of automatically memorizing the subtotal mileage. Turn off the power switch, the subtotal mileage will not be automatically cleared, but after the battery is disconnected, the subtotal mileage will be automatically reset.

1

2

3

4

5

6

7

8

























9

10

11

12

Indicator and warning light

Serial No.	Icon	Description	Serial No.	Icon	Description
1		Left turn indicator	20		Vehicle stability system off indicator (if configured)
2		Far-beam indicator	21		Vehicle stability system working indicator (if configured)
3		Low-beam indicator	22		Motor fault warning light
4		Right turn indicator	23		Power battery off indicator
5		Rear fog lamp indicator	24	TPMS	TPMS fault warning lamp
6		Charging cable connection indicator	25		System fault warning lamp
7		Charging status indicator	26		Position lamp indicator
8		Parking indicator and brake system malfunction warning lamp	27		Co-driver's seat belt warning lamp
9		Power battery fault warning lamp	28		Driver's seat belt warning lamp
10		12V battery fault warning lamp	29		Safety airbag fault warning lamp
11		EPB fault warning light	30		BSD fault indicator
12	AUTO HOLD	AUTOHOLD indicator	31		Battery charging state indicator
13		Limited power indicator	32		HMA indicator (Yellow/Green)



Serial No.	Icon	Description	Serial No.	Icon	Description
14		CCS indicator	33		Electronic gear failure warning light
15		Power steering system fault warning lamp	34		LDW indicator (Yellow/Green/White)
16		ABS fault warning lamp	35		Front collision warning system indicator
17	READY	Driving status indicator			
18		Pedestrian warning system fault indicator			
19		Abnormal tire pressure warning lamp			

1

2

3

4

5

6

7

8

9

10

11

12

Check indicator/warning light

Close all doors, pull up the parking EPB switch, and turn the power switch on.

The following indicators / warning lights will be lighted up:



The following indicators / warning lamps will be lighted up briefly for a few seconds and be extinguished:



If the above indicators/warning lights are not lit, it indicates that the indicators/warning lamps fail or the vehicle circuit is open. Please contact JAC authorized after-sales service store.

Indicator



Left and right turn indicator

When turning the combination switch turn signal / multi-functional control lever or pressing the hazard warning flash lamp switch, the left and right turn indicator will be lighted up.

▲Attention: When you send a turn signal or press the hazard warning light switch, the green flash light is not flashing or flashes too quickly, check the fuses and indicator and replace them if necessary.



Far-beam indicator

When the far beam light is on or the turn signal/multi-functional control lever is pulled into the flash-overtaking position, the high beam indicator is on.



Low-beam indicator

This indicator is on when the low beam lamp is on.



Rear fog light indicator

When the rear fog light is on, this indicator is on.



Charging cable connection indicator

When the charging cable connection indicator is lighted on, it indicates the charging cable connection is correct. When the charging cable is unreliable or not connected, the charging cable connection indicator goes out.

Note:

- The vehicle can not enter the READY state when the charging cable connection indicator is on.



Charging status indicator

If the charging status indicator is lit while the vehicle is running, the battery needs to be charged as soon as possible.



▲ Attention: During charging, the power switch is set to "ON" and the charging status indicator of the instrument is also on, indicating that the power battery is charged successfully and the charging current is stable. If not, it indicates the charging is over or interrupted.



Limited power indicator (Turtle lamp)

When the power battery is low, the turtle light is on. Please charge it as soon as possible.

When the vehicle's driving power is limited, the turtle light is on. Please drive slowly.



Parking indicator light

When parking, the parking status indicator lights up.

When parking is released, the parking status indicator is off.

When the vehicle is in the process of running, this light suddenly lights up, indicating the brake system failure. Please park the vehicle in a safe area, and contact JAC authorized after-sales service store.



Driving status indicator

Depress the brake pedal, press the power switch to START, the vehicle high-voltage circuit is conducted (powered on), the driving status indicator lights up. In the driving process, the driving status indicator keeps on.

▲ Attention: Driving status indicator may be off due to:

- Electrification system fault.
- When the power battery is out of power, the driving indicator will be off, please charge it immediately.



Position light indicator

When the position light is on, this indicator is on.



Vehicle stability system off indicator (if configured)

The light is on, indicating that the vehicle stability control system is off.

In the following special circumstances, the ESP function needs to be turned off:

- When the vehicle is running with a snow chain.
- When driving on deep snow or on a soft surface.
- When the vehicle is stuck somewhere and needs to move back and forth to get out of trouble.



Vehicle stability system working indicator (if configured)

When the vehicle stability system works, the indicator flashes.

When the vehicle stability control system fails, the vehicle stability system working indicator is always on.



Power battery off indicator

Power battery off indicator lights up, indicating that the vehicle high-voltage circuit is disconnected.

1

2

3

4

5

6

7

8

9

10

11

12



CCS indicator (white/ green)

Cruise control is used to alert the state of driver's car's cruise control system.

When the cruise control system is turned on, the indicator is white; when the cruise control system is activated, the indicator is green.

Warning light



Pedestrian warning system fault indicator

If the indicator is on, indicating there is a problem, please contact JAC authorized after-sales service store.



Power steering system fault warning lamp (yellow/red)

When the power switch is placed in the ON gear, the power steering system fault warning light is on and goes out after a few seconds, indicating that the power steering system is normal. When the power steering system is initialized, the indicator light is yellow; When the alarm light remains lit, it indicates that the power steering system has a fault. Steering assist is reducing or disappearing, but you can still control the vehicle. Especially when in cornering or low speed, you need to use more force to turn the steering wheel. Park the vehicle in a safe place and contact JAC authorized after-sales service store.

Note:

●If the 12V lead-acid battery is removed and the vehicle is powered on again, the indicator light is yellow and it needs to re-zero calibration. After the extinguishing of indicator, the system can be used normally.



ABS fault warning lamp

When the vehicle is powered on, the ABS fault warning light will be turned on and go out after a few seconds, indicating that the ABS system is normal.

When the warning light remains on or it is off when the power switch is ON, it indicates that the ABS system is malfunctioning. At this time, the brake system can still work normally, but the anti-lock braking system does not work. Please contact JAC authorized after-sales service store immediately.

▲**Attention:** If the brake anti-lock system fault warning light stays on, the ABS system may have a fault. You should avoid sudden brake, and please contact JAC authorized after-sales service store immediately.



AUTOHOLD indicator

When the green indicator is always on, it means that the AUTO HOLD function is activated; when the green indicator is flashing, it means that the AUTO HOLD function is in working state; when the red indicator is on, it means that the AUTO HOLD function is abnormal.



EPB fault warning light

When EPB parking brake system has failure, the warning light lights up, please contact JAC authorized after-sales service store.



TPMS fault warning lamp

This light indicates that the system is faulty and the sensor power is low. Please contact JAC authorized after-sales service store.



Tire pressure abnormal warning light

This light indicates the high pressure, low pressure or high temperature alarm of the tire;

This lamp flashes fast to indicate tire leakage, please contact JAC authorized after-sales service store.



Brake system fault warning light

When brake system failure occurs, the light lights up, please contact JAC authorized after-sales service store.

▲Attention: If the tire pressure is significantly reduced, it will cause unstable driving or poor control, thus extending the braking distance. Continued driving of the vehicle in this state will result in overheating of the tire and even accidents.



System fault warning lamp

When vehicle control system failure occurs, the system failure warning light will be lit. Please contact JAC authorized after-sales service store immediately.



Motor fault warning light

When motor system failure occurs, the system failure warning light will be lit. Please contact JAC authorized after-sales service store immediately.



Power battery fault warning lamp

When the power battery failure occurs and the power battery failure warning light is on, please contact the JAC authorized after-sales service store.



12V battery fault warning lamp

When the key is placed in ON, the warning light is on, if it goes out after a few seconds, it indicates that the 12V lead-acid battery is normal.

When the warning light remains on, the 12V lead-acid battery has low power or a DCDC failure. Please park the vehicle in a safe place. And please contact JAC authorized after-sales service store immediately.

1

2

3

4

5

6

7

8

9

10

11

12



Driver's seat belt warning lamp

When the power switch is set to ON, the main driver's seat belt is not fastened and the light is on.



Co-driver's seat belt warning lamp

When the power switch is placed in the ON position, there is a passenger on the co-driver's seat and the seat belt is not fastened. The light is on.



Safety airbag fault warning lamp

The airbag failure warning light illuminates when the airbag system fails or is not installed.



BSD fault indicator (if configured)

When the blind spot detection system fails, the BSD fault indicator is on.



Battery charging state indicator

When the battery capacity is too low, the indicator light of power battery is on.



Automatic low and far beam lamp switch indicator (if configured)

When the automatic low and far beam lamp switch system fails, the indicator is yellow; When the system is activated, the indicator is green.



Electronic gear failure warning light

When the electronic gear system fails, the electronic gear failure warning light is on.



LDW indicator (Yellow/Green/White) (if configured)

Yellow lights will be lit when the lane deviates from fault; When the LDW system fails, the indicator is yellow; When the system is on and not activated, the indicator is white; When the system is activated, the indicator is green.



Front collision warning system indicator (if configured)

When the front collision warning system fails, the indicator is yellow; When there is a risk of collision, the red indicator is on.

Voice reminder

When the vehicle is in the READY state and the gear is in the D or R, the vehicle stops for more than 60s, the instrument sounds "beep - beep"; the sound prompts for more than 10s or the vehicle restarts, the sound stops.



Combination switch

Turn lamp switch

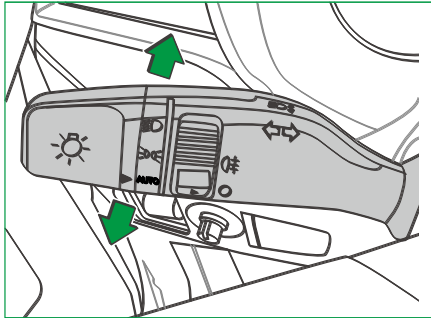

The turn lamp works only when the power switch is on.

If the vehicle needs to turn left, please turn the light joystick down; if you need to turn right, turn the light joystick up. The corresponding turn indicator on the combination instrument will flash at the same time.

After exiting the curve and turning the steering wheel back, the turn signal joystick and indicator will be automatically reset.

Headlamp switch

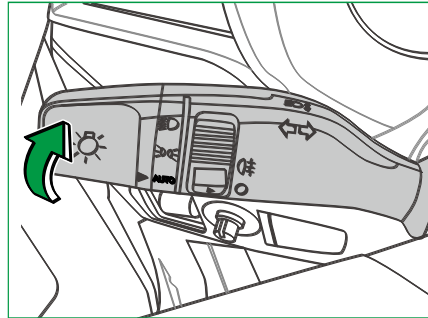

You can control the lamp by rotating the barrel-shaped switch at the end of lamp joystick. When the barrel-shaped switch is turned to the ☀ position, the position lamp, license plate lamp, instrument and the background lamp of the center control table can be turned on. The headlamp can be turned on by turning the lamp joystick to the position ☀D .

⚠ Attention: When the headlamp switch is in any position above, the position lamp will remain on when the key is removed. It is recommended that you check whether the headlamp switch is on the OFF position before getting off the vehicle to avoid the discharged battery and malfunction of the vehicle.

1

2

3

4

5

6

7

8

9

10

11

12

High beam lamp switch

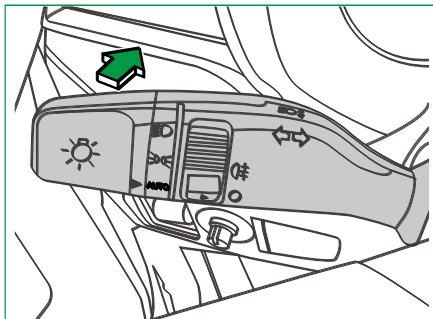

Turn the barrel-shaped switch at the end of the lamp joystick to the position  and push the lamp joystick forward (away from the driver) until you hear a click. The high beam of headlamp will be on. While the high beam of headlamp is turned on, the high beam indicator on the instrument will also light up. If you want to switch back to low beam lamp, you can pull back the lamp joystick.

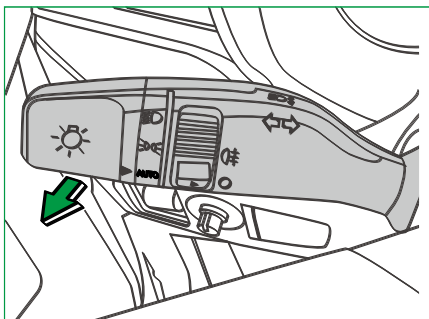

Headlamp flash

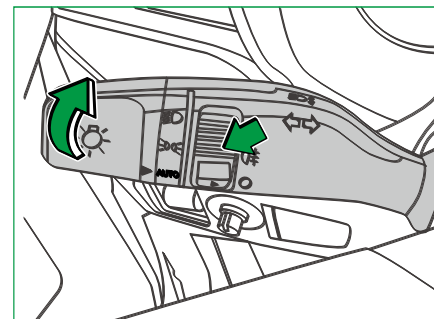

To make the high beam lamp flash, gently pull the lamp joystick toward the driver's side and release it. Meanwhile, the high beam lamp lights up and then goes out. Even if the lamp joystick is on the OFF position, the headlamp can also flash. If you hold the lamp joystick to the driver's side, the high beam lamp will stay on for as long as you hold it.

Fog lamp switch



The fog lamp switch is located on the lamp joystick. When the terminal barrel-shaped switch is turned to the position , Rotate the middle switch of the joystick to the position  to open the rear fog lamp, meanwhile the  (rear fog lamp sign) lamp on the instrument lights up as a reminder, and then the switch will return automatically. Rotate the switch to the position of rear fog lamp to close the rear fog lamp.



AUTO lighting

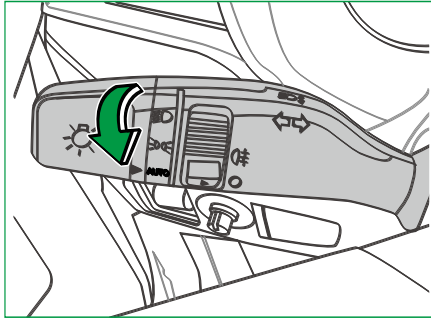

When the rotary switch is turned to the AUTO, the automatic headlamp control system is activated, and the low beam lamp, the position lamp and the background lamp are automatically turned on and off according to the lighting of external environment.

When the outside is dark(eg: the vehicle enters dusk, night, tunnel, etc.), the brightness sensor monitors that the ambient light is below a certain brightness, and the low beam lamp, position lamp and background lamp light up automatically. When the outside is bright again, the above lamps are turned off with a delay.

▲ Attention: - Fog, mist and smoke can affect the brightness. So the brightness sensor can not detect it precisely at daytime with heavy fog. The auto headlamp function may not work. Please turn on the headlamp manually for clear vision and safe driving.

- The headlamp may be lighted because of alternate changes of light and shade when the vehicle passes through bridge hole and shade.

Front windshield wiper

▲ Attention: - If the wiper is frozen during frost, do not turn it on, otherwise the wiper blade and wiper motor will be damaged.

- Do not use the wiper when the window is dry, otherwise the wiper blade may wear out or be damaged quickly.

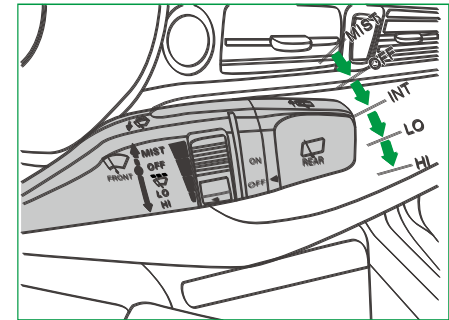

The joystick is used to control the windshield wiper and washer. When the power switch is located on the ON position, the windshield wiper and the washer are in working condition. The joystick includes five shifts: MIST: Inching wiping

1

2

3

4

5

6

7

8

9

10

11

12

Instrument and Control

OFF: Off

INT: Intermittent wiping

LO: Low speed wiping

HI: High speed wiping

Inching wiping

If the wiper is operated in jog mode, push the lever up from the OFF position and the wiper will wipe the water at high speed until you release the lever.

Intermittent wiping

Move the joystick downward to INT and adjust the interval time by rotating the knob on the joystick.

Low speed wiping

Move the joystick downward to the LO, and the wiper moves at a low speed.

High speed wiping

Move the joystick downward to the "HI" position, and the wiper moves at a high speed.

Close front windshield wiper

Move the joystick to OFF and the wiper stops working.

Rear windshield wiper

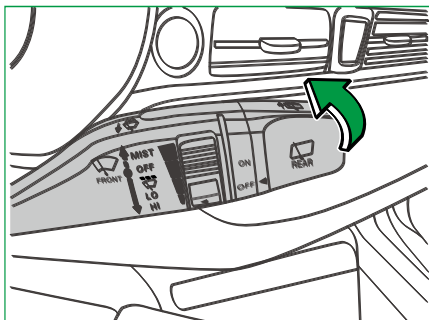

Turn the wiper control handle knob clockwise to ON to turn on the rear wiper.

Note:

- Before using the windshield wiper in winter or freezing weather, make sure that whether the blade is frozen on the window.

Windshield washer

Front windshield washer

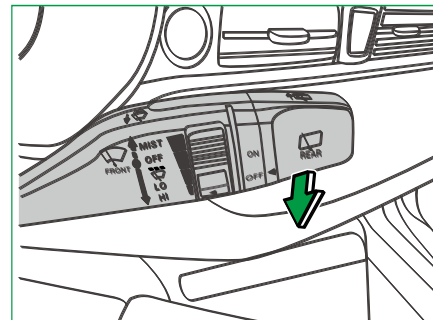

If you pull the joystick towards the driver, the washer will keep sprinkling water and wiper will keep swaying at a low speed until the joystick is released. The wiper will wipe for several times after you release the joystick.



Rear windshield washer

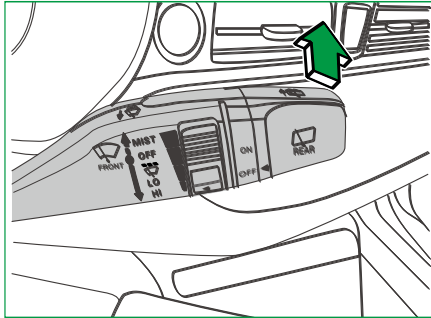

Push the joystick away from the driver, the washer will keep sprinkling water and the wiper will keep swaying until the joystick is released.

The wiper will wipe once again after you release the joystick.

⚠ Attention: - The water washer shall not work for more than 15 seconds every time, and it is prohibited to operate the washer when there is no cleaning fluid in the kettle.

- Anti-freeze windshield cleaning fluid should be used in freezing areas in winter.
- The wiper could stop working because of the ice or other obstacles on the window during work, which may cause the wiper motor to burn out. When this happens, stop the vehicle immediately, turn off the power switch, and clean the windshield so that the wiper can work freely.

Multi-functional steering wheel

Left buttons

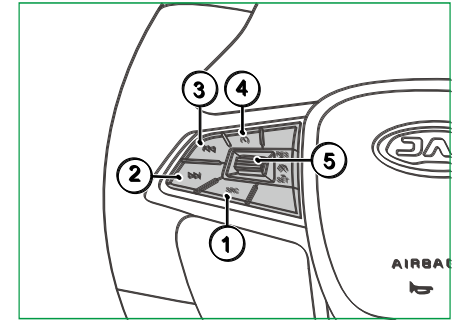

1. Press this button to change the sound sources.
2. Press this button to change to the next track or channel.
3. Press this button to change to the previous track or channel.
4. Press this button to enable cruise control (the instrument displays a white symbol). When the vehicle speed reaches to the set value, it will be in cruise control.

1

2

3

4

5

6

7

8

9

10

11

12

5. Wheel button operation:

- Press the middle wheel button to cancel the cruise control.
- Turn the wheel button up to resume cruise control and increase cruise speed.
- Turn the wheel button down to set cruise speed and reduce cruise speed.

Right buttons

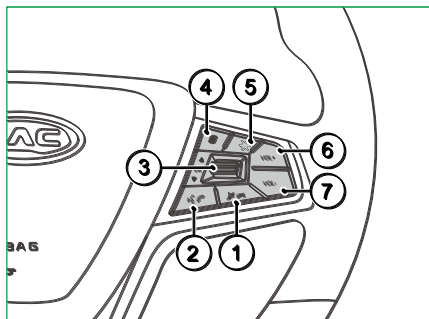

1. The phone function is only available for models equipped with Bluetooth phones and voice recognition systems. When enabled, press this button to shut down the voice system; on a Bluetooth phone and during a call, press this key to terminate the call or reject the call. Press this key to mute when the infotainment system is working.

2. This button only applies to models equipped with Bluetooth phones and voice recognition systems. When the Bluetooth phone is not activated, press this key to

start the voice system; when the Bluetooth phone is enabled and there is telephone access, press this key to receive the telephone.

3. Wheel button operations:

- Press the middle wheel button to confirm the contents displayed by the combination instrument.
- Turn the wheel button up to change contents upper displayed by the combination instrument.
- Turn the wheel button down to change contents lower displayed by the combination instrument.

4. Press this button to turn pages of the contents displayed by the combination instrument.

5. Press this button for skin change with one button/capture with one button (which can be set by multimedia display screen).

6. Press this button to raise the volume of the loudspeaker.

7. Press this button to reduce the volume of the loudspeaker.



Left lower switch group

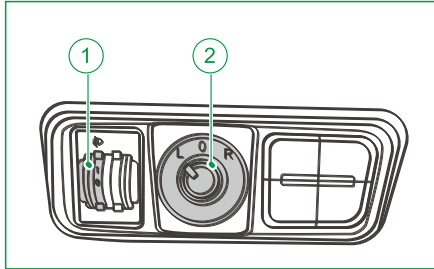

1. Headlamp height adjustment switch:
After the headlamps are turned on, the headlamp adjustment height can be adjusted by rotating the headlamp adjustment switch. Rotate the roller from 0 to 6 gear to adjust the illumination height from highest to lowest.
2. Rear view mirror adjustment switch:
move the lever to L or R to select the left rear-view mirror or the right rear-view mirror for adjustment, and force the switch to move up and down or left and right to adjust the angle of the rear-view mirror in the four directions.

Hazard warning flash light switch

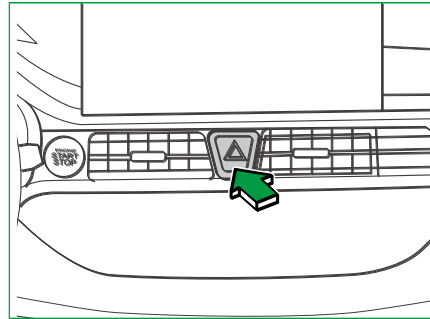

The hazard warning flash light switch is located under the central vents on the dashboard with a triangular mark. Hazard warning flash light can be activated even after the vehicle is powered off. Hazard warning flash light can be used in the following situations:

- Emergency;
- Your vehicle is blocked;

The vehicle is in an unsafe condition due to a malfunction;

Driving a vehicle in rain, snow, fog or low visibility environments;
- Park the vehicle in non-safety parking areas for some reason.

Note:

- After the hazard warning flash light switch is pressed, the steering indicator on the meter flashes.
- When the hazard warning flash light is on, the corresponding turn signal is lit when the turn signal and the lane change signal lever is changed.

1

2

3

4

5

6

7

8

9

10

11

12

Interior illumination

Front roof lamp

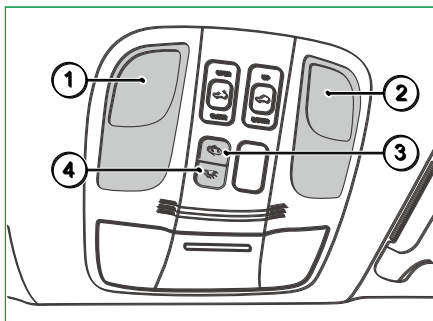

1. Left reading lamp switch: Press it to turn the left reading lamp on or off.
2. Right reading lamp switch: Press it to turn the right reading lamp on or off.
3. Door control switch: Press it to turn the door control switch on or off. When the door control switch is on, the illumination lamp works when any door is open, and it will be off only when all the doors are closed.
4. Interior lamp switch: Press it to turn the interior lamp on or off.

Rear roof lamp

The rear roof lamp switch is a push-button type with ON and OFF modes. The ON mode is a long mode of lighting and the OFF mode is a long mode of going out. When the door control switch of front roof lamp is turned on, the roof lamp will light up when any door is open.

Logo lamp

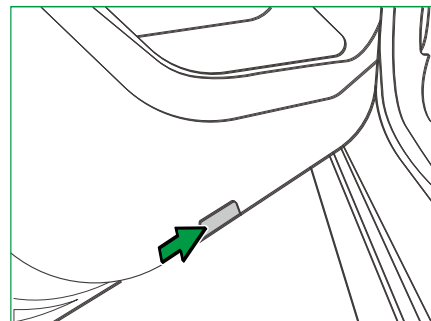

When any door is open, the corresponding Logo lamp will work. And it will go out after the door is closed.

▲ Attention: Do not use the interior lamps for a long time when the power system is not running, otherwise the battery will lose power.



Vehicle lamps

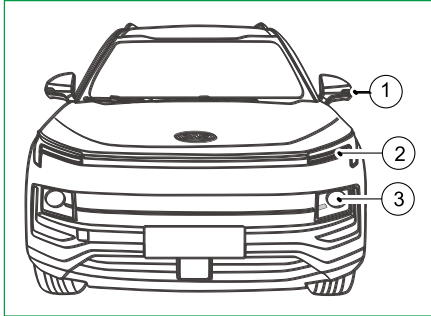

1. Turn lamp
2. Front position lamp/daytime running lamp/Front turn lamp
3. High/low beam lamp

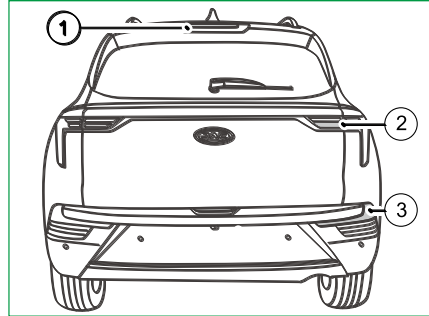

1. High brake lamp
2. Rear combination lamp
3. Rear fog lamp and retro-reflector

Low beam lamp

The low beam lamp is used to ensure your safety while driving with poor visibility or in dark.

High beam lamp

The high beam is used to help you know the long-distance road condition at night or in a poor visibility (Please switch to low beam lamp when meeting a vehicle).

Daytime running lamp

Daytime running lamp is mainly used during the day to improve the visibility of the vehicle during daytime driving. When the power switch is on the ON position and the parking is released, the daytime running lamp is on. When the position lamp is on, the daytime running lamp is dimmed.

Front turn lamp

The front turn lamp is used when turning or changing lanes.

1

2

3

4

5

6

7

8

9

10

11

12

Bulb replacement

1. Disconnect the battery's negative terminal.
2. Turn the front turn lamp holder counterclockwise to remove the bulb.

▲ Attention: - To avoid sudden movement of the vehicle, finger burned by the bulb, or fire caused by the motor, before replacing the lamp, you should pull up the EPB switch, adjust the power switch to LOCK, and turn off the lamp until the bulb's heat is dissipated.

- During the replacement of all the bulbs, the battery's negative terminal must be disconnected first to avoid damage to the lamp and the wiring harness inside the vehicle. Please replace the burnt bulb with a new one with the same rated wattage, otherwise it will result in damage to the fuse or circuit system.

- If you have no professional tools, bulb with needed power and relevant operating skills, please carry out maintenance at the JAC authorized after-sales service store. In many cases, it is hard to change lamps, for you have to take many other parts down in advance, especially if you have to disassemble the front

combination lamp assembly to access the lamp. Removing or installing the front combination lamp assembly may damage the vehicle.

- When driving in rain or after your vehicle is washed, the interior of the lamps may be foggy. The mist inside the lamp cover will disappear gradually after the lamp has been working for some time. The mist has no impact on the life of illumination system.

- Do not shake or turn the lamp during disassembly.

- High/low beam lamp, position lamp and daytime running lamp use enclosed LED lamp sources, which cannot be replaced by conventional methods. In the event of a malfunction, please submit this work to the JAC authorized after-sales service store. When operating the lamp, only hold the bulb's plastic holder, and do not touch the shell.

Electric adjustment of headlamp

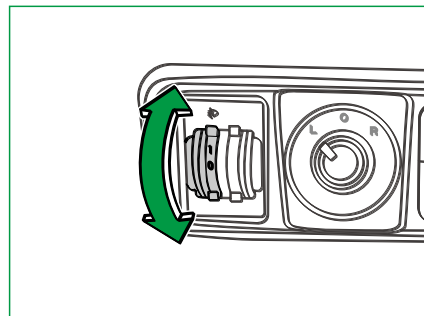

The distance of the low beam illumination can be adjusted in the cab, and the adjustment switch is located on the switch panel on instrument on the left side of the steering wheel.

The distance of the low beam illumination can be adjusted by adjusting the switch to adapt to the different vehicle pitch attitudes caused by different vehicle weight. As the gear position increases, the low beam illumination distance decreases.

**Note:**

- The vehicle start switch should be turned to ON to adjust the lamp adjustment switch.

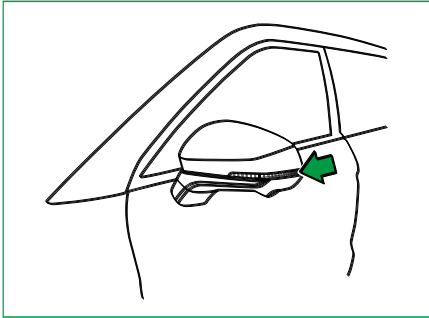
Turn lamp

Turn lamp shows your driving direction for the side drivers and pedestrians.

Note:

- In wet or cold weather, or when the vehicle is exposed to rain or after washing, there may be extremely small water droplets, water mist or white mist (condensation) inside the lampshade:
- This situation is a normal phenomenon that water vapor in the high temperature air in the lamp condenses when it is cold.
- When the vehicle is parked in a dry environment or lamps are on, and the vehicle is running, the water vapor will gradually evaporate and there may be residuals at the corner of the lamps.
- This phenomenon does not affect the service life of the vehicle's lighting unit, and you do not need to change the lamp assembly.

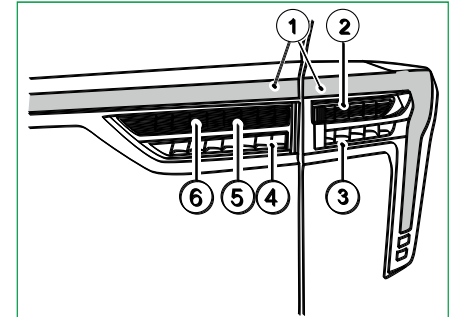
Rear combination lamp

1. Rear position lamp
2. Rear turn lamp
3. Brake lamp
4. Brake lamp*
5. Rear turn lamp*
6. Reversing lamp

1

2

3

4

5

6

7

8

9

10

11

12

Rear turn lamp

Prompt your driving direction for the driver and pedestrians at the rear.

▲ Attention: If you want to make a turn, please switch on the turn lamp 50-100m ahead of the curve or crossroad, informing the rear drivers and pedestrians of the moving direction of your vehicle, to avoid traffic accident.

Reversing lamp

When the reverse gear is engaged, the reversing lamp is automatically lighted.

Brake lamp

Brake lamp is used to remind and warn the drivers and pedestrians of the road condition ahead.

Replacement of rear combination lamp bulb:

1. Remove the rear combination lamp.
2. Turn the rear turn lamp holder counterclockwise to remove the turn lamp bulb.

3. Turn the reversing lamp holder counterclockwise to remove the bulb.

Rear position lamp

Rear position lamp is used at dusk, dawn or environment with poor visibility.

▲ Attention: The position lamp and brake lamp use enclosed LED lamp sources, which cannot be replaced by conventional methods. In the event of a malfunction, please submit this work to the JAC authorized after-sales service store.

Rear fog lamp and retro-reflector

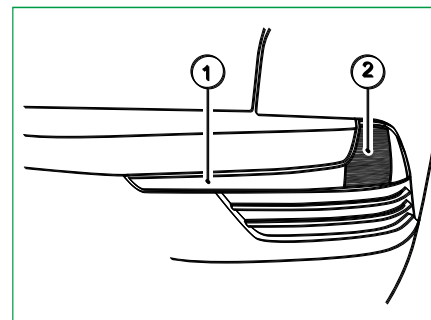

1. Retro-reflector
2. Rear fog lamp

The rear fog lamp is used to prompt the rear drivers and pedestrians with your vehicle's information to avoid unnecessary traffic confusion or accident when visibility is poor.

Rear fog lamp bulb replacement:

1. Disassemble rear bumper.
2. Rotate the lamp holder counterclockwise to remove the lamp holder.
3. Remove the fog lamp bulb from the bulb holder.
4. Replace the lamp and reinstall the lamp holder.



High brake lamp

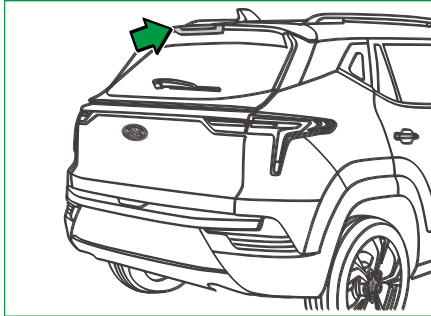

High brake lamp is used to supplement the indication and warning of brake lamp.

Note:

- The high brake lamp uses enclosed LED lamp source, which cannot be replaced by conventional methods. In the event of a malfunction, please submit this work to the JAC authorized after-sales service store.

Position lighting

Turn on or off the position lighting function in "Vehicle setting" of MP5.
ON: The position lamp will work after unlocking the vehicle with the remote control key, and will go out if the driver's door is opened in 30s or the vehicle is locked again.

Follow me home

When the power system is off, turn the overtake lamp switch within 30s to activate the low beam lamp instantly. You can set the low beam delay time of following me home in "Vehicle setting" of MP5.

Note:

- If the low beam lamp is activated by following me home function, it will go out immediately when the power state changes.

Power saving function

Avoid the problem of discharged battery because of long-term non-start of the vehicle in which the lamps has been lit up. When the vehicle is in OFF state and no operation is done for more than 15 minutes, the vehicle will enter the power saving mode and the lamps go out inside the vehicle.

When the door is opened or closed, or when the vehicle is unlocked or locked, the interior lamps will be re-lit.

▲ Attention: Even with the power saving function, it is not recommended to turn on the lamps and electrical appliances for a long time when the power system is not started. When the vehicle is not started, long time working of lamps and electrical equipments will reduce battery's power and cause malfunction of vehicle in severe cases.

1

2

3

4

5

6

7

8

9

10

11

12

Anti-theft system

Start the anti-theft system

Take the following steps to activate the anti-theft system

- The vehicle is powered off;
- Close doors, windows, front hood and tailgate;
- Use the left front door handle switch or smart key to lock;
- All vehicle doors are locked;
- Anti -theft system is started;

Take the following steps to prevent accidental activation of the alarm

- Press the unlock or lock button on the smart key, or use the mechanical key to insert the left front door lock cylinder to lock or unlock;
- The alarm will be activated when the door lock is opened in any other way.

Disarm the anti-theft system

Take the following steps to activate the anti-theft system

- Use mechanical keys to open driver side door lock;
- Press the smart key unlock button;
- Press the left front door handle switch;
- All doors will be unlocked;
- Anti-theft system is disarmed;

How to close the anti-theft alarm

If the anti-theft alarm starts, use any of the following methods to clear the alarm.

- Use mechanical keys to open driver side door lock;
- Press the smart key unlock button;
- Press the left front door handle switch.



6

Inspection before driving

● Keys	94	● Window	108
● Door	95	● Sunroof.....	110
Door lock.....	95	Panoramic sunroof	111
Control button of central door lock	96	Common sunroof.....	112
Remote control door lock system.....	97	● Sun visor	112
Remote search	98	● Rear-view mirror.....	113
Keyless entry system.....	98	Inner rear view mirror	113
Child safety device	99	Outer rear view mirror.....	114
● Front hood.....	101		
● Tailgate.....	102		
Tailgate opening	102		
Tailgate closing.....	105		

Keys

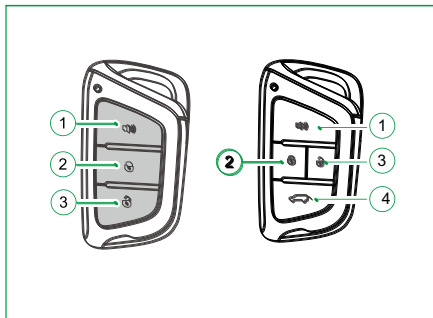

1. Search button
2. Lock button
3. Unlock button
4. Tailgate unlock button*(Electric tailgate button)

You get two keys along with the vehicle you bought.

You can use either one of remote control keys to remotely control and unlock the vehicle.

Please leave another key in a safe place for spare use in case the key is damaged, loss, or locked in the vehicle.

Note:

- Please leave the remote control key away from sunshine, high temperature and moisture for the sake of electronic parts protection. Avoid the key dropping from high place and heavy weights placed above.

- For sake of safety, you are suggested to go to JAC authorized after-sales service store to copy the key and only use the key billet admitted by JAC.

- If you need an extra key or if you lose your key, as long as you can provide the key number, JAC authorized after-sales service store can prepare a new key for you.

Warning

- Even if you are only temporarily leaving the vehicle, be sure to carry the key with you.

- Do not leave children and key in the vehicle alone, for children may start the power system, turn on the power switch, operate the power windows and other electrical equipments in the vehicle. This may cause serious injury to children and others.

- Do not pull the key before the vehicle is completely stopped, or the steering wheel locking mechanism would be triggered by accident, leading to steering failure.



Door

Door lock

Open and close the left front door with a mechanical key

1. Take out the mechanical key.



Smart key: To take out the mechanical key, press the release button and take out the key.

Common key: To take out the mechanical key, press the release button and the mechanical key will be taken out automatically.

Note:

- Do not fold the common key without pressing the release button for fear of the key damage.

⚠ Attention: - Please leave the remote control key away from sunshine, high temperature and moisture for the sake of electronic parts protection.

- Avoid placing the key with metals or hard matters in case of failure occurs.

- Do not leave children and key in the vehicle alone, for children may start the power system, turn on the power switch, operate the power windows and other electrical equipments in the vehicle. This may cause serious injury to children and others

2. Insert the mechanical key into the lock cylinder and rotate it clockwise.

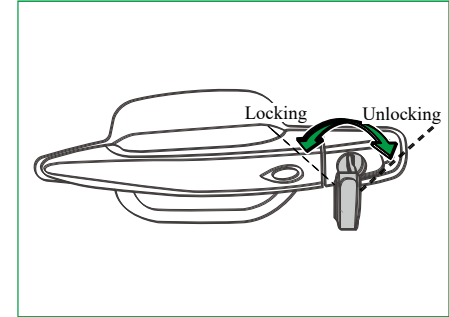

When the door is locked with a key outside the vehicle, the four doors are locked by inserting the key and turning it counterclockwise.

Turn the key clockwise when unlocking, then pull the door handle outward to open the door.

1

2

3

4

5

6

7

8

9

10

11

12

Inspection before driving

Note:

- When leaving an unattended vehicle, all doors must be locked and keys must be removed. When the door is locked by the key, the vehicle anti-theft system is activated.

Lock the door with the inner door handle

In the absence of a key, when the door needs to be locked, the left front door can be locked by pressing the inner handle lock button and pulling the left front door outer handle, closing the door, so that the door can be locked; for other three doors, press the inner handle lock button and close the door, then the door can be locked.

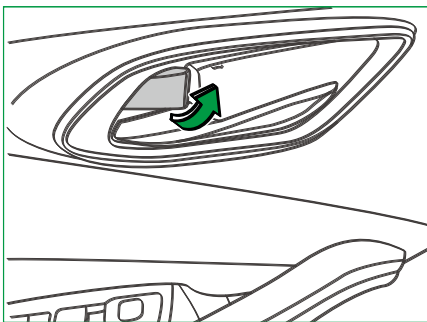

Note:

- The anti-theft system is not started in this way to lock the doors. Please be careful not to leave the key in the vehicle in this way to lock the door.

When the door lock button is in an unlock state, you can open the door by pulling the handles inside or outside the vehicle.

Control button of central door lock

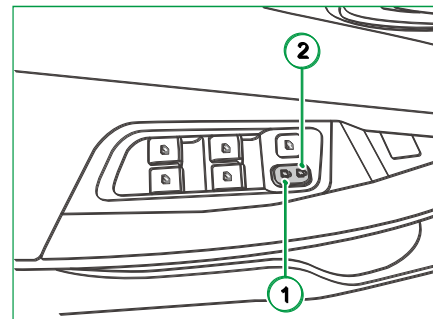

Door lock control button on the driver's side can control four doors' lock. Press the front of the control button (part 2), four doors are locked; press the back of the control button (part 1), and four doors are unlocked.



Remote control door lock system

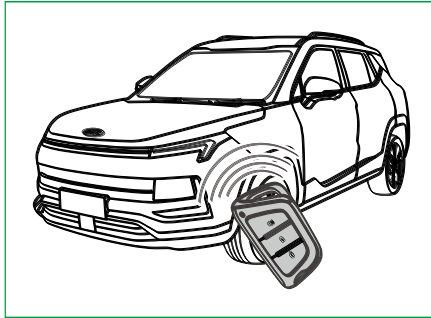

With the radio remote control unit on the key, several functions can be realized without using a mechanical key, such as locking, unlocking and finding the vehicle, unlocking the trunk, regulating the windows and so on.

Locking

Close all doors (including the tailgate), and short press the lock button  on the key once within a valid range, all the doors (including the tailgate) will be locked at the same time, the turn signal light will flash, and the horn will sound to show the vehicle is in a state of alert.

Unlocking

Short press the unlock button  on the key once within a valid range, all the doors (including the tailgate) will be unlocked at the same time, and the turn signal light will flash twice to indicate the release of alert status.

Note:

- When the left front door of the vehicle is not closed, the vehicle does not perform the lock action.
- If any of the other three doors except the left front door, and tailgate is not closed well, the vehicle can be locked but does not enter the state of alert after you press the lock button on the remote controller. After the door is closed, the vehicle enters the alert state.
- After the alert state of vehicle has been released by remote control, please open the door within 30s, or all doors(including the tailgate)will be locked automatically.
- Due to the continuous improvement of theft technology, it is suggested to pull the handle once to check whether the door is locked well after using the remote control lock.

1

2

3

4

5

6

7

8

9

10

11

12

Inspection before driving

Remote search

1. Press the search button  on the smart key briefly (for the smart key with search button) or press the lock button twice in one second when the vehicle was locked (for the smart key with electric tailgate unlock button) within the valid range.
2. The left and right turn signals flash 3 times at the same time, then the left and right turn signals flash 3 times and the horn sounds 3 times.

Keyless entry system

Keyless locking

1. Close all the doors (including the tailgate).
2. Bring the smart key to the vehicle and press the micro switch on the left front door handle.
3. All doors (including the tailgate) are locked at the same time, the turn signal light flashes, and the horn sounds to indicate that the vehicle is in the alert state.

Note:

- When the left front door of the vehicle is not closed, the vehicle does not perform the lock action.
- If any of the other three doors except the left front door, and tailgate is not closed well, the vehicle can be locked but does not enter the state of alert after you press the micro switch on the handle. After the door is closed, the vehicle enters the alert state.

Keyless unlocking

1. Bring the smart key to the vehicle and press the micro switch on the left front door handle.
2. All the doors (including the tailgate) are unlocked at the same time, and turn signal lamps flash twice to show that the vehicle is out of the alert state.

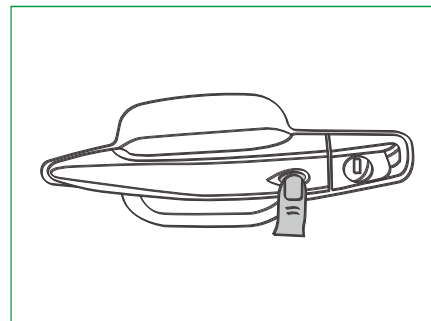

Note:

- After pressing the micro switch to release the vehicle from being in alert status, please perform the door opening action within 30 seconds. Otherwise, all doors (including the tailgate) will be automatically locked.

Automatic locking after leaving function

The vehicle is equipped with automatic locking function after leaving with the key. If the automatic locking function is set to open, the vehicle will automatically lock after leaving with the key. It can be set in "Vehicle Settings" on the MP5 screen. Automatic lock function trigger: ① the



vehicle is power-off; ② Close the driver's door; ③ Carry the smart key out of the vehicle sensor range for more than 10 seconds.

- ▲ Attention:** - The access function does not work properly under the following conditions:
1. After pressing the micro switch on the outer door handle to lock the vehicle, press the micro switch again in a short time, the unlocking action will not be performed, and vice versa.
 2. After the vehicle is locked by the central locking, the keyless function will be disabled.
 3. After the vehicle is locked with a remote control key in vehicle, the keyless function will be disabled.
 4. After the vehicle is locked with a mechanical key, the keyless function will be disabled.
 5. When the smart key is on the other side of the door handle being touched.
- This method must be carried out under the premise that the vehicle power supply can work normally.
 - Only the outer handle of left front door has this function, and the remaining door outer handles do not have this function.

⚠ Warning

- If there is another key in the vehicle at this time, the vehicle will not be automatically locked.
- When there is a key in the vehicle and another legal key is outside the vehicle, and when someone presses the micro switch on the door handle to perform the keyless lock, the vehicle will automatically be unlocked with alarm.

Child safety device

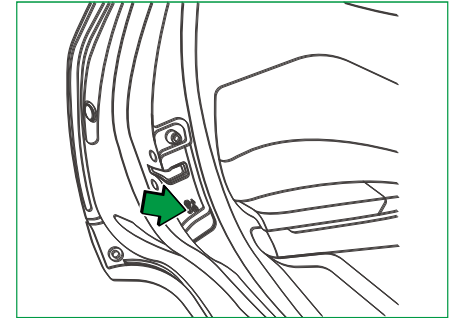

The two rear doors of the vehicle are equipped with the child safety door locks. The function of child safety lock is to prevent passengers (especially children) away from pulling the interior door handle and accidentally open the door inside the vehicle, which would cause unnecessary damage. It is recommended to use the device when the backseat is taken by children.

1

2

3

4

5

6

7

8

9

10

11

12

Set the child safety device

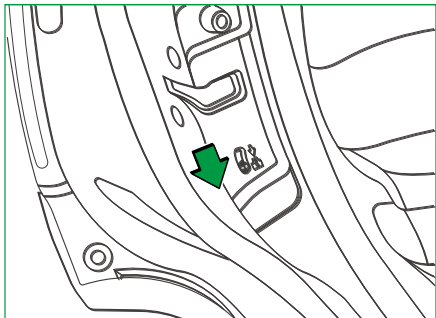

When setting the child safety lock, the child safety lock at the rear edge of the door must be lowered to the position before closing the door. At this point, the door can only be opened by pulling the exterior handle outside the door.

Release the child safety device

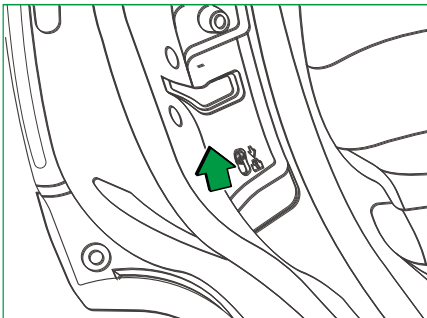

If you want to unlock the safety lock, first open the door from the outside of the vehicle and turn the child safety lock at the rear edge of the door to the reverse position.

Warning

- When the child safety device is activated, do not forcibly pull the door handle of the car, which may damage the handle.
- It is dangerous to unlock the doors. Before you drive the vehicle (especially there are children in the vehicle), make sure all doors are closed and locked up to avoid doors being suddenly opened. Closing the door and using the seat belt at the same time can avoid the danger of passengers being thrown out in an accident.
- Before opening the door, you need to observe the surrounding traffic conditions to avoid accidents.



Front hood

The front hood lock opening handle is located on the lower left side of the driver's instrument panel. The operations of opening and closing are as follows:

1. Pull the front hood handle.

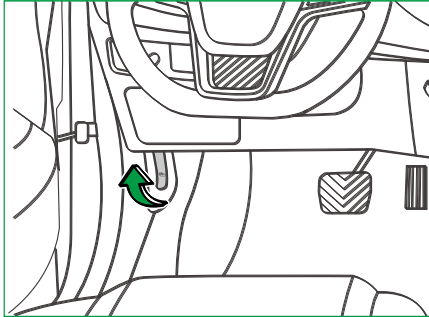

2. Extend your hand to the inside of the front edge of the front hood and pull the safety lever to the left to lift the hood.

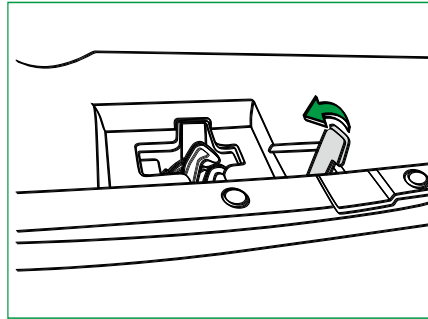

3. Raise the front hood to the maximum position and prop up the strut rod.
4. When close the front hood, remove the hood strut rod and return it to the strut buckle. Hold the front edge of the hood with your hand and put it down slowly. Release the front hood when it is 30cm away from front front bumper to lock it during free fall. Finally, lift the hood up and check whether the hood is closed and locked. If it is not locked, you have to repeat the above steps.

Warning

- Before driving, confirm whether front hood is locked, or the hood may open and block your horizon during driving and it will cause accidents.
- Do not drive vehicle when front hood is lifted, because the hood will block your horizon, or drop down and be damaged.
- Please do not pull the front hood release handle when driving the vehicle.
- When the front hood is open, remember to insert the end of strut rod into the hole.

1

2

3

4

5

6

7

8

9

10

11

12

Inspection before driving

Tailgate

Tailgate opening

Ordinary tailgate opening

Method 1:

When the key is outside the vehicle and the vehicle is in a locked state, place the key in the induction range of the vehicle, and softly press the unlock button  on the key to release the tailgate, and then the turn signal lamp will flash twice to show the release of alert.

Press the electronic switch on the upper part of the tailgate handle recess and lift up the tailgate.

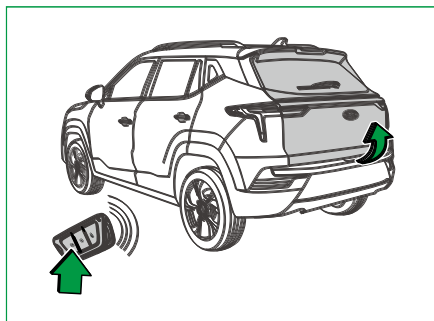

Method 2:

Carry the smart key and press the electronic switch on the upper part of the tailgate handle recess and lift up the tailgate.

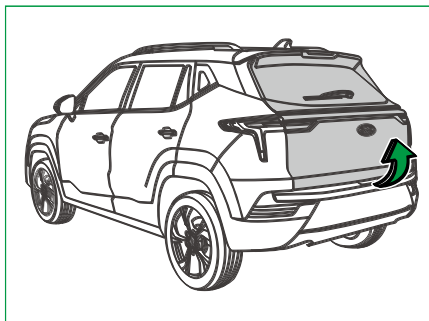

Method 3:

When the person is trapped inside the tailgate, or in an emergency such as power failure, find the emergency opening cover and open it in the lower middle position of the tailgate, then turn the emergency opening button of tailgate lock in the direction of the arrow to open the tailgate.

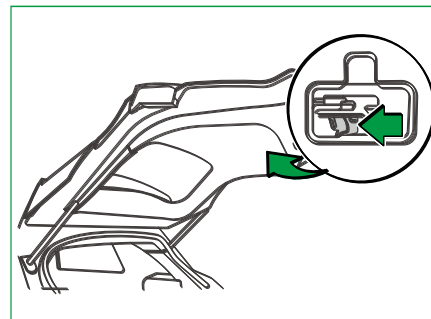



Electric tailgate opening*

Open the tailgate by exterior handle

In the unlock state, press the tailgate exterior handle switch to open the tailgate. The remote key is needed in the lock state.

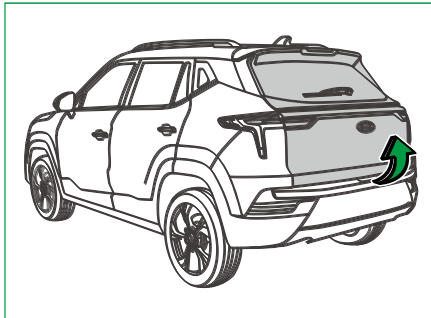

When a person is trapped inside the tailgate, or in an emergency such as power failure, find the emergency open handle cover which locates in the lower middle of the tailgate and open it, then turn the emergency open handle to the left of the driving direction to open the tailgate.

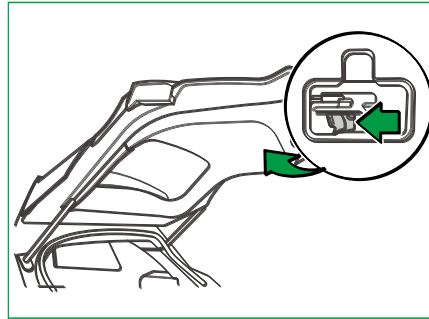

Control by smart key

When the tailgate is closed, long press the electric tailgate button for more than 2 seconds to open tailgate; when it is being opened, long press the button for more than 2 seconds to stop it; then long press the button for more than 2 seconds to close it.

When the tailgate is open, long press the electric tailgate button for more than 2 seconds to close tailgate; when it is being closed, long press the button for more than 2 seconds to stop it; then long press the button for more than 2 seconds to open it.

As the electric tailgate has self-protection function, when it is going to be locked completely, you can not stop it by pressing the electric tailgate button.

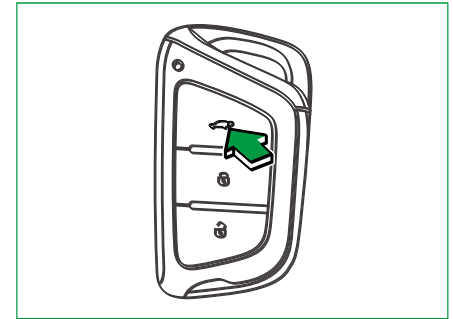

1

2

3

4

5

6

7

8

9

10

11

12

Inspection before driving

Open by kick switch

Take the remote key and trigger the kick switch, the tailgate will be opened automatically.

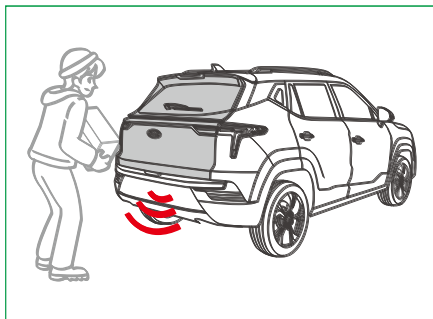

Note:

●Kick switch only works in the constant electric state and a remote key is needed.

The process of a complete kick switch opening operation:

1. Stand within the detecting area of the sensor, normally $300\text{mm}\pm 100\text{mm}$ from the rear bumper (depending on the user's convenience).
2. Lift the feet up close to the rear bumper.
3. Lift the feet up close to the kick antenna smoothly with a distance of $50\text{mm}-100\text{mm}$ before stopping, the feet are not required to touch the rear bumper.

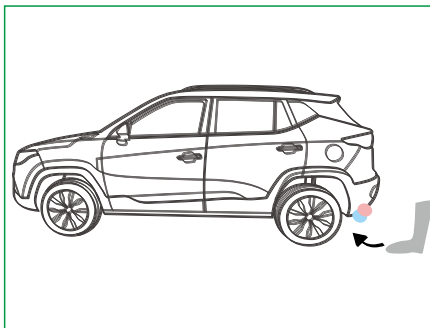

4. Move feet back to original position. A complete kick operation is finished.
5. The whole kick lasts for $0.2\text{s}-2.5\text{s}$.

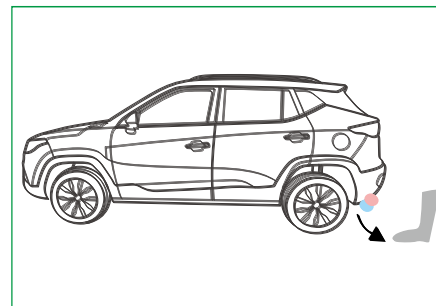

Notice: the followings are wrong kick operation:

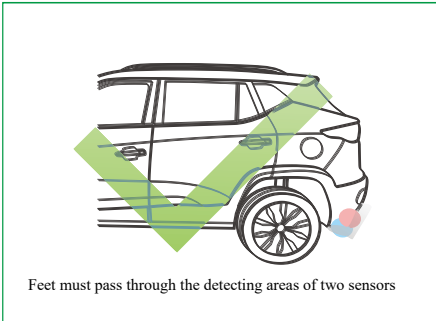
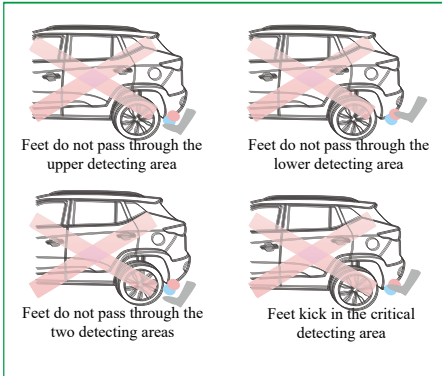

Tailgate closing

Ordinary tailgate closing

Stand at the tail and ensure that the heads and other parts of you and other persons are away from the movement area around the tailgate. Pull the tailgate interior handle or the edge of the sheet metal to pull the tailgate downward, and operate it with both hands as the closure angle increases. The tailgate can be closed by its self-weight or slight force.

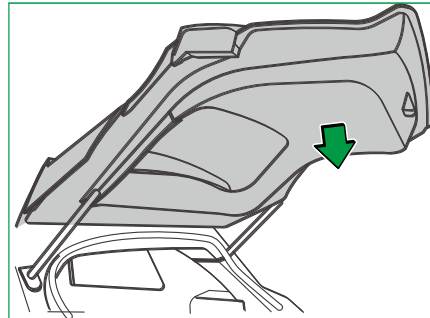

Electric tailgate closing*

Close tailgate by interior handle

Pull the tailgate interior handle to close tailgate, the handle can be held by both hands as the close angle increases.

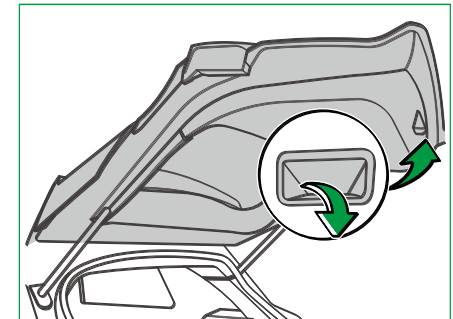

- 1
- 2
- 3
- 4
- 5
- 6
- 7
- 8
- 9
- 10
- 11
- 12

Inspection before driving

Close by tailgate switch

Close tailgate by switch at the lower edge of tailgate, if the tailgate is in closing process, press the switch, then the tailgate will start opening process.

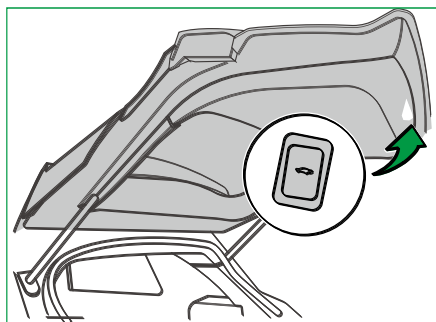

Open angle set

If the open angle of tailgate need to be set, please do as the following instructions: open the tailgate manually and keep it at the height to be set on, press the tailgate switch at the lower edge of tailgate for more than 3 seconds until the buzzer rings three times.

Reset

The electric tailgate need to be reset under following circumstances:

1. Battery is cut off.
2. Low battery voltage or battery discharged.
3. tailgate was not in lock state after it was manually closed.

Reset method of electric tailgate:

1. Cut off the battery for 30s and then reconnect the battery.
2. Close the tailgate manually till it is in lock state.

Anti-pinch

Anti-pinch clips are installed on both sides of the upper electric tailgate; if the electric tailgate system encounters obstacles, the tailgate system will move reversely.

Warning

- Warning in the driving:
- Keep the tailgate closed in the driving. If the tailgate is open, the tailgate may hit objects around or the baggage may accidentally eject when you are driving, causing an accident.
- Before driving the vehicle, make sure the tailgate is completely closed. If the tailgate is not fully closed, it may accidentally open during driving, causing an accident.
- Never let anyone sit in the trunk. Otherwise, a serious injury or even death may occur in an emergency braking or collision.
- Please observe the following precautions when children are in the car, otherwise there maybe serious injury or even death.
- Do not leave a child alone in the trunk; A child may get heatstroke when left alone in the trunk.
- Do not let a child open or close the tailgate, otherwise it may cause accident move of tailgate or the child get pinched battery tailgate.



Warning

- Please observe the following precautions when operating electric tailgate, otherwise it may cause serious injury or even death. Before opening the tailgate, the heavy load on the tailgate, such as snow and ice, should be removed first; otherwise, the tailgate may suddenly be closed again after being opened.
- Before opening or closing the tailgate, make sure the surrounding area is safe. If someone is nearby, make sure that they are safe and let them know the tailgate is about to open or close.
- Be cautious when opening or closing the tailgate in windy weather, because the tailgate may suddenly move in strong wind.
- If the tailgate is not fully opened, it may be suddenly closed; opening and closing the tailgate on the ramp is much more difficult than on the flat ground, so beware of accidental opening or closing of the tailgate. Make sure the tailgate is fully opened and fixed before using the trunk.
- Be cautious that fingers do not get pinched

Warning

- when closing the tailgate.
- Do not pull the tailgate air spring pole to close the tailgate and do not hold the tailgate air spring pole; otherwise the air spring pole may be broken or hands get pinched.
 - If a bicycle rack or similar heavy object is attached to the tailgate, the tailgate may suddenly be closed again after being opened, thereby clamping the person's hands, head or neck and causing injury.
 - Please observe the following precautions of anti-pinch function, otherwise it may cause serious injury or even death.
 - Prohibit activating anti-pinch function with any part of your body deliberately.
 - If the window pinches the object before it is about to be closed completely, the anti-pinch function may not work. Do not pinch fingers or other objects. The anti-pinch function may not work because of the unique shape of pinched objects. Do not pinch fingers or other objects.
 - Please observation the following

Warning

- precautions when opening the tailgate by kick switch(with kick sensor), otherwise it may cause serious injury or even death.
- Do not open the tailgate by kick switch if there is snow or ice on the ground, or else you may fall.
 - If the key is near tailgate, for your safety, please pay attention to the following operations which may cause the tailgate open mistakenly:
When washing or wipe the car, water or hand approaches the sensor frequently; An animal, a wet object or metal object approaches and leaves the sensor detecting area;
 - Maintenance staff goes under the rear bumper to do maintenance;
 - Pick something from under the rear bumper;
 - Walk or run through the tailgate.

1

2

3

4

5

6

7

8

9

10

11

12

Inspection before driving

▲ Attention: - If the tailgate is closed manually immediately after it is opened, the resistance force may be big.

- If the element tailgate system is not working under the following three conditions, the instrumentation will alarm that the electric tailgate system unavailable. If you want to use it, please check whether it meets the requirements of opening.

1. ON power, open the tailgate at 5km/h.
2. Enter the violence mode, trigger the switch.
3. Temperature overshoot, trigger the switch.

- Keep the electric tailgate system from damage.

- Make sure there is no ice between tailgate and door frame which may obstruct the movement of tailgate. If there are heavy objects on the tailgate, operate electric tailgate system may cause malfunction.

- Do not apply big force on the tailgate when the electric tailgate system is working.

- Do not damage the anti-pinch strip when using a knife or other sharp objects. Otherwise the anti-pinch function may fail.

Window

When the power switch is in ON, the electric windows are in a controllable state.

Main switch is located on driver's door panel, and separate window switch has been equipped on correspondent door panel.

To prevent passengers from operating windows randomly, one unlock/lock switch for all windows has been equipped on main control panel.

▲ Attention: - Do not open the main switch and the secondary switch along different directions at the same time, or the window will stop and cannot be opened or closed.

- When a child is in the vehicle, please use the power window lock switch to avoid injury caused by child's operation.
- When you leave the vehicle, make sure the windows are closed.
- Be careful of being pinched when you close the window(even if your vehicle is equipped with anti-pinch function).

Main switch control panel

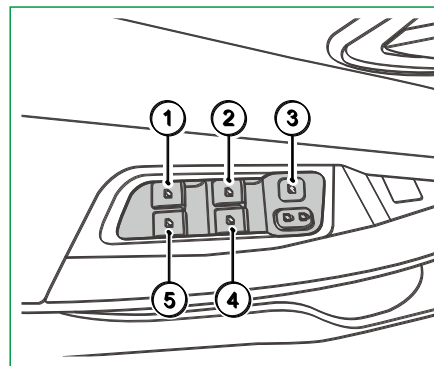

1. Lifting switch for left-rear window
2. Lifting switch for left-front window
3. Locking switch for window's lifting: Pressing this button will make the passengers in co-driver's and rear seats unable to use their window lifting switch. But the driver still have control on all the windows in the lock state, and if you press the locking switch again, the normal operation on windows will be restored.
4. Lifting switch for right-front window
5. Lifting switch for right-rear window



Four-window lifting with one click

The window lifting switch has the function of lifting all windows with one click. Pull up or press down the first gear for manual lifting or lowering, and pull up or press down the second gear for automatic lifting or lowering.

The second gear is on the highest or lowest position, and the first gear is between the regular position and the second gear position. You can sense the gear feeling between the first gear and the second gear.

Window anti-pinch and one-click lifting function learning

When the vehicle's power is turned off and then turned on again, the window lifter needs to be initialized. Turn the power switch to ON; lower the window to the bottom; manually pull up the button to raise the window to the top, and keep the button at the top position for not less than 2 seconds, and then pull down the button to lower the window to the bottom (During the initialization process, when the window is manually raised, it is normal for it to rise step by step).

After the anti-pinch function learning is completed, the window can be lifted or lowered with one click. The vehicle with high configuration is equipped with four-window anti-pinch function. The four-window anti-pinch function must be learned before the remote control window function can be realized.

Anti-pinch function

As the self-learning of window anti-pinch is completed, when the window is being closed, the anti-pinch function will be activated with a resistance in anti-pinch area, and the max allowable force is no more than 100N.

▲Attention: - Prohibit activating anti-pinch function with any part of your body deliberately.

- If the window pinches the object before it is about to be closed completely, the anti-pinch function may not work.

1

2

3

4

5

6

7

8



9

10

11

12

Remote control of window lifting

1. Close all the doors(including tailgate).
2. Long press the lock button  on smart key in effective range, or shortly press the lock button  to lock the vehicle and then long press the lock button .
3. All doors (including the tailgate) are locked at the same time, the turn signal lamps flash, and the horn sounds to indicate that the vehicle is in the alert state.

Note:

●Short press: Press the button once. Long press: press the button for more than 2 seconds.

In the process of remote control of window lifting, the window can be stopped by pressing any key on the smart key, and the lock button  on the smart key can be pressed again to complete the command of window lifting.

 **Attention:** - In the case of ACC and ON, the remote control function cannot work properly.

Alarm for remote control of window lifting

When the window is being lifted in remote control, the vehicle will give an alarm in the following circumstances:

1. The anti-pinch function of any window works.
2. Any window can not be lifted to the top.
3. Window anti-pinch and one-click lifting functions are not learned.

Thermal protection for motor of power window

If the window is operated repeatedly in a short time, the power window control switch will fail for protecting the motor. Wait for about 20 seconds to restore it, and then the power window can be operated again.

Sunroof

The sunroof can be controlled when the power switch is in ON or the front hood is working.



Panoramic sunroof

Sunroof sliding operation

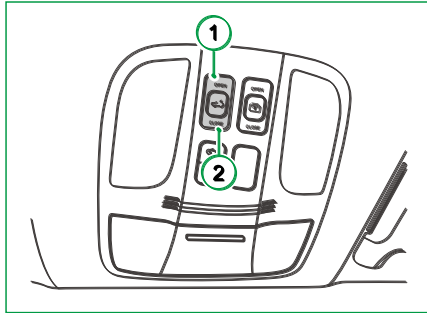

- ① Sunroof open
- ② Sunroof close

Short press the switch of the sunroof and the sunroof will stop moving after automatically sliding a certain distance.

Long press the switch of the sunroof and then release, the sunroof will slide automatically until it is fully open or closed. Press any switch and the sunroof will stop moving.

Sunroof tilting operation

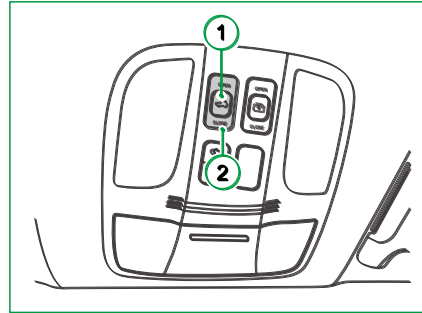

- ① Open the sunroof aslant
- ② Close the sunroof aslant

Press the tilting switch of the sunroof and the sunroof will be closed or tilted. After releasing the switch, the sunroof will stop moving.

Sunroof anti-pinch

The sunroof has an anti-pinch function in the sliding area and tilting area. When the sunroof closes against an obstacle, the sunroof immediately stops moving and then moves in the opposite direction for a certain distance before stopping.

Sunroof sunvisor curtain

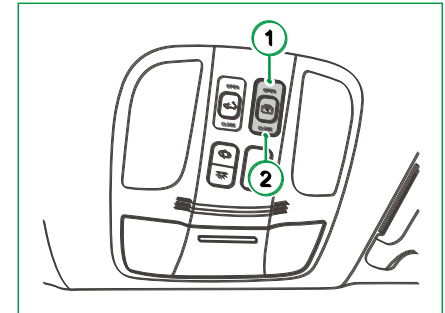

- ① Sunroof sunvisor curtain open
- ② Sunroof sunvisor curtain close

Short press the switch of the sunroof visor and the sunroof visor will stop moving after automatically sliding a certain distance.

Long press the switch to open or close the sunvisor curtain, release it, and the sunvisor curtain will start to move until it is fully open or closed. Press any switch during this period, and the sunvisor curtain will stop moving.

1

2

3

4

5

6

7

8

9

10

11

12

Common sunroof

Sunroof sliding operation

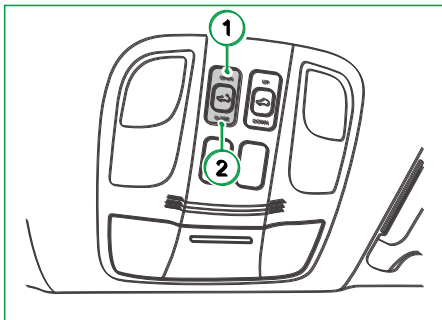

- ① Sunroof open
- ② Sunroof close

Short press the switch of the sunroof and the sunroof will slide automatically until it is fully open or closed. Press any switch and the sunroof will stop moving.

Sunroof tilting operation

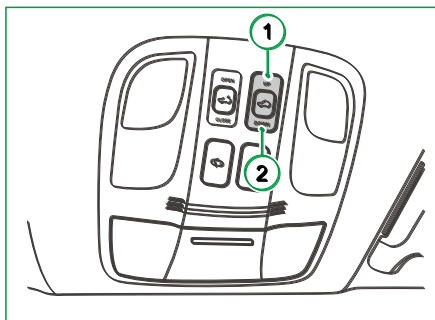

- ① Open the sunroof aslant
 - ② Close the sunroof aslant
- Short press the tilting switch of the sunroof and the sunroof will be closed or tilted. Press any switch and the sunroof will stop moving.

Sunroof sunvisor curtain

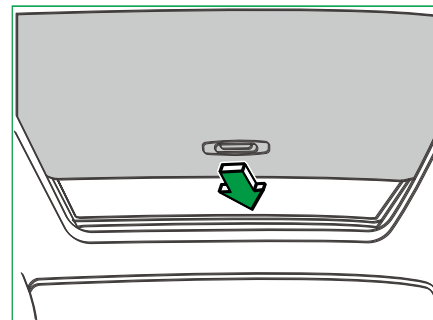

The sunroof sunvisor curtain can be opened and closed by hand. When the window opens, the sunvisor curtain opens automatically. If the sunvisor curtain is to be closed, manual operation is required.



Sun visor

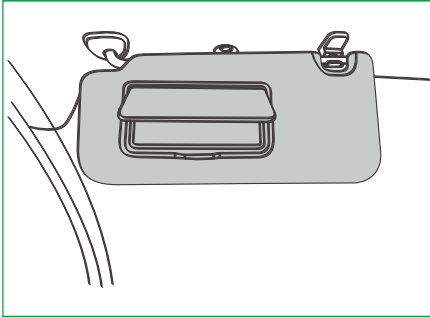

In order to shield the front and side sunlight for the driver and passenger on co-driver's seat, two sun visors are equipped in front of the driver's and co-driver's seats.

Flip down the end of the sun visor to open the sun visor and keep it on the desired position. Push it back to the original position if the sun visor is not used.

When the sun visor is open, open the middle cover to use the cosmetic mirror. There are airbag sign and relevant description on co-driver's sun visor.

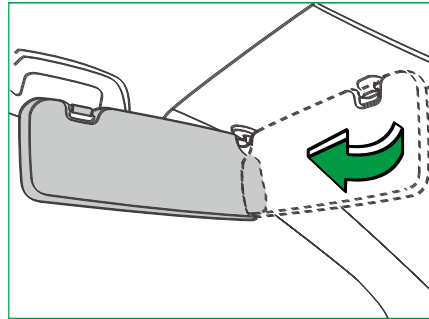

To shield the sun from the side, you can pull the sun visor out from the side bracket and turn it around towards the door.

Rear-view mirror

Inner rear view mirror

After choosing a comfortable driving position, catch the middle of the mirror to move up and down or left and right to adjust the rear-view mirror to get a clear rear vision. If it doesn't meet the requirement, adjust the ball near the base to meet the demand.

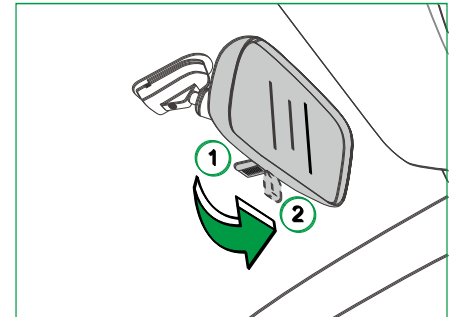

Daytime normal position 1: The end of anti-dazzling operating handle points to the front windshield.

Nighttime anti-dazzling position 2: The

1

2

3

4

5

6

7

8

9

10

11

12

Inspection before driving

end of anti-dazzling operating handle points to the rear-view mirror.

▲Attention: - Use tissue or similar substance with glass cleaner to clean the rear-view mirror. Do not spray the glass cleaner directly to the rear-view mirror, otherwise the liquid cleaner will enter into the shell of the rear-view mirror.
- Unclear rear view in driving will cause collision accident, damaging your vehicle and other properties and risking human`s life.

Outer rear view mirror

▲Attention: - The outer mirrors can expand the field of vision to see the surrounding objects and other vehicles; if you can not correctly determine the distance between your vehicle and other objects, it may lead to accidents. Please adjust to appropriate position before driving.

- Improper maintenance of the exterior mirrors may cause damage. If the mirror surface is frozen, do not scrape it. If ice or other objects limits the movement of the mirror, do not make adjustments forcedly. Please use deicing agent or heater to remove ice.

Electrical adjustment for exterior rear-view mirror

Rear-view mirror`s electrical adjustment switch is located on the left lower switch group. You can adjust the positions of left and right exterior rear-view mirrors by this switch in the vehicle.

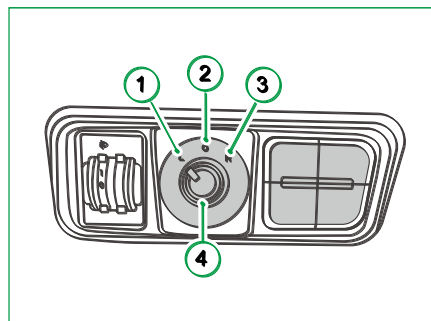

1. L: Select this gear to adjust the position of the left exterior rear-view mirror.
2. O: The position of the left and right exterior rear-view mirrors can not be adjusted when you select this gear.
3. R: Select this gear to adjust the position of the right rear exterior rear-view mirror.



⚠ Attention: - You are supposed to keep the rear-view mirror in a properly adjusted state and use them in driving to enlarge your view and get a better vision of surrounding objects and other vehicles.

- If you can not judge the distance correctly between your vehicle and other objects, it may result in collision accident, and damage your vehicle or other properties, or cause injury.

- Improper maintenance of rear-view mirror will cause damage. Do not scrub off the ice on the surface of rear-view mirror. Forced adjustment is prohibited if the ice and other objects have a restriction on the movement of rear-view mirror.

⚠ Warning

- Do not adjust the rear-view mirror in driving.
- In the movement of rear-view mirror, be careful that fingers are not to be clamped by rear-view mirror to avoid injuries and rear-view mirror failure.

Exterior rear-view mirror heating

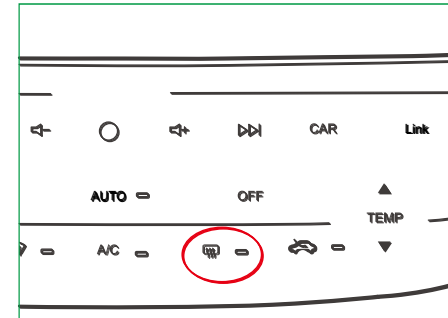

After turning on the power switch, adjust the air conditioning button to the defrost mode. The heating function of the exterior mirror is turned on to eliminate the mist and water vapor on the exterior rear-view mirror.

This function only works when the vehicle is in the "ON" position. After turning on for 20 minutes, the heating function will automatically turn off. You can also press this button to turn off this function in advance.

- 1
- 2
- 3
- 4
- 5
- 6
- 7
- 8
- 9
- 10
- 11
- 12





7

Ventilation and A/C system

● A/C system.....	118	1
Basic instruction.....	118	2
Air conditioner outlet layout.....	120	3
Air conditioning control system.....	121	4
Outlet adjustment.....	125	5
Passenger compartment air filter.....	125	6
● Infotainment system.....	125	7

A/C system

Basic instruction

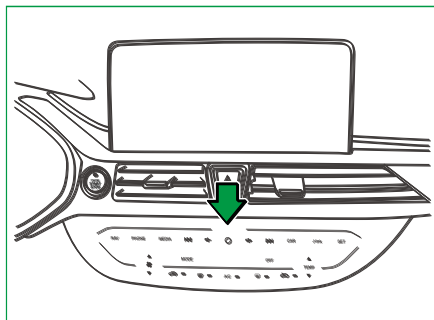

A/C equipment can heat, cool and dehumidify the air in the vehicle. When the windows and the movable skylight are closed, the A/C equipment has the highest working efficiency. Ventilation can accelerate cooling with accumulated heat in the vehicle.

When the air conditioner is turned on for cooling with high humidity air and high temperature outside, it is normal that the condensate will drip from the air conditioner evaporator and form stagnant water at the bottom of the vehicle.

Note:

- When the A/C button is pressed, the indicator on the button is extinguished to indicate that the air conditioner compressor stops working.
- Closing the air conditioner compressor in proper condition can save fuel and reduce exhaust of harmful objects.
- In order not to affect the heating or cooling power and to prevent the appearance of water mist on the window, it must be ensured that there is no snow or leaves blocking the air inlet in front of the windshield.

- ▲**Attention:** - The A/C system needs to be filled with JAC accredited refrigerants by JAC authorized after-sales service store's professionals.
- The maintenance of A/C system components needs to be operated by JAC authorized after-sales service store's professionals.

▲**Attention:** - The air in the vehicle will be vented through the vents near the rear side window. Therefore, please pay attention to prevent clothing and other objects from blocking the air vent, resulting in poor air circulation.

- When the windows are closed, the A/C system can work more efficiently. However, when the vehicle is stationary and at a high temperature due to strong sunlight, opening the window for a short period of time can help speed up the cooling process.

- If the vehicle often enters and goes to places with more sediment, please check and clean the vehicle in time. The sediment below the chassis is more likely to cause the compressor clutch sucker to enter the sediment and cause locking failure.

- Please be careful to prevent children from mistakenly inserting debris, such as papers and coins, into the air duct from the air outlet of the air conditioner, which may cause abnormal noise.

**Warning**

- The absence of ice, snow and water fog on all windows is crucial for traffic safety. Therefore, please be familiar with the proper operation of warm air and ventilation devices, window dehumidification and defrosting, and cooling operation modes.
- In order to improve the cooling effect, the internal air circulation mode can be switched on for a short time, but not for a long time, because the "dirty" air may make the driver and the occupant tired and distracted. And it may cause the window to be covered with water mist, increasing the risk of accidents. Once the window is covered with water mist, turn off the air circulation mode immediately.
- In the air circulation mode, fresh air will not enter the vehicle. After the refrigeration unit is turned off, the window quickly freezes with water mist in internal air circulation mode, which may seriously affect the visual field, leading to accidents!

Warning

- When a vehicle is parked in a garage or places with poor airflow, please turn on internal air circulation mode to prevent outer air from entering into the vehicle, which may cause poisoning.
- The dirty air inside vehicle will cause driver to be exhausted soon and distract his attention, which may lead to traffic accidents and personal injury.
- Do not turn off the blower for a long time and do not use the internal air circulation mode in the vehicle for a long time.
- Otherwise, fresh air could not enter the vehicle.
- When you do not need to use the internal air circulation mode, turn it off.

1

2

3

4

5

6

7

8

9

10

11

12

Air conditioner outlet layout

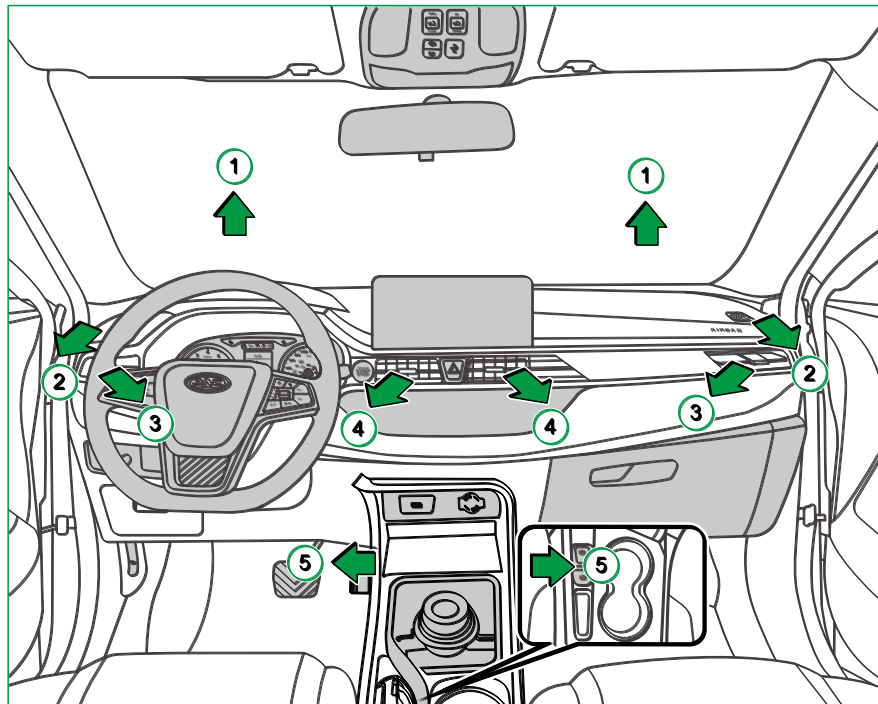

1. Front windshield defrosting /defogging air outlet
2. Side defrosting / defogging air outlet
3. Side air outlet
4. Central air outlet
5. Floor air outlet



Air conditioning control system

The A/C heating and cooling system can work only when power system and air blower are working.

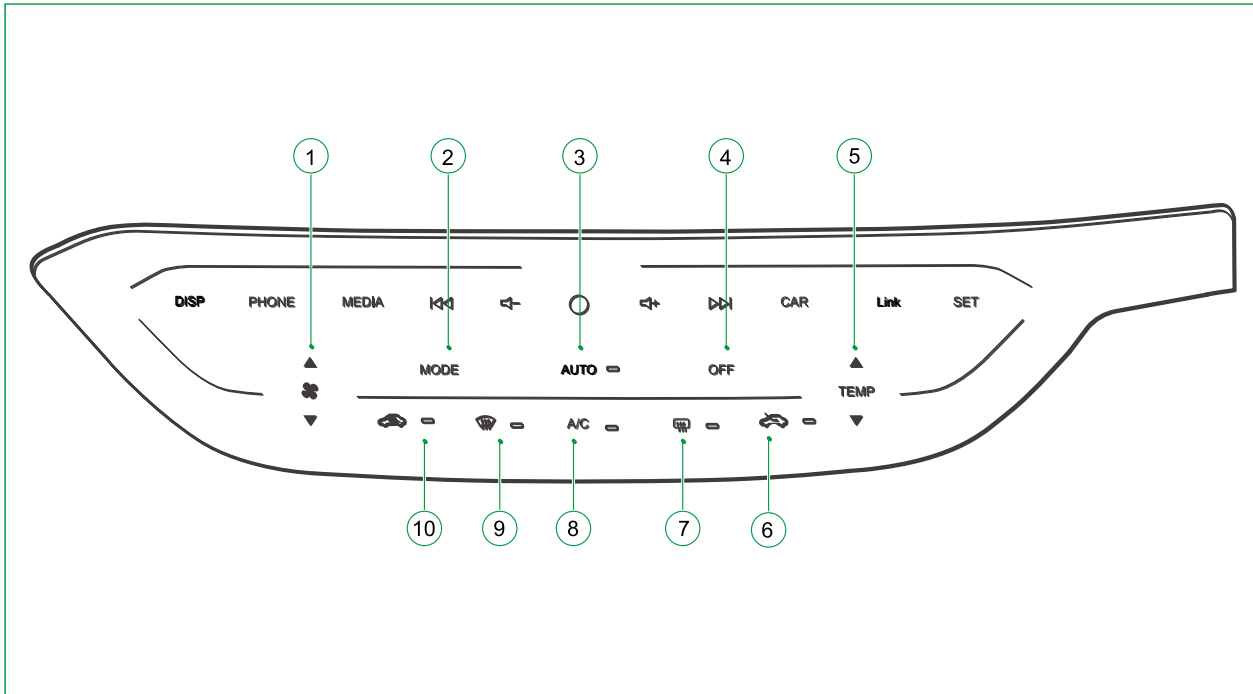

1

2

3

4

5

6

7

8

9

10

11

12

1. Air volume adjustment button: press the upper button to increase air volume; press the lower button to reduce air volume.
2. Mode button: press it to adjust the outlet modes of air condition. The modes are switched by repeating operations in face-blow, face-blow&foot-blow, foot-blow, foot-blow and defrosting modes.
3. AUTO button: Press this button and the air conditioner is in full automatic control.
4. OFF button: press it to turn off all the function of the air conditioner.
5. Temperature adjustment button: press the upper button to increase temperature; press the lower button to decrease temperature.
6. Outer circulation button: press it to enter into outer circulation mode.
7. Rear defrosting button: it controls the working of rear defrosting switch and the exterior mirror heating switch.
8. A/C button: it controls the working of air condition compressor.
9. Front defrosting button: press it to turn on defrost mode.
10. Inner circulation button: press it to enter into inner circulation mode.

Air conditioning compressor switch

A/C Press this button to turn the air conditioner compressor on or off. When the A/C button is pressed, the indicator on the button will light up to indicate that the air conditioner compressor has started to refrigerate. Press this button again to turn off the air conditioner compressor. When the weather is hot, open the window to let the hot air out of the vehicle and then close the window. This helps to shorten the time required for vehicle cooling and also helps to improve the system's operating efficiency.

If you cannot start the refrigeration unit, there may be the following reasons:

1. Power system is not started.
2. Blower is off.
3. Air-conditioning fuse is damaged.
4. If there are other failures, please go to the JAC authorized after-sales service store to check the A/C system.



Inner circulation mode



This mode can switch ventilation to inner circulation mode, which can prevent outer air and bad smell from entering into the vehicle and increase/reduce the inner air temperature more quickly. Press this button to turn on or off the inner circulation mode, which may cause fogging on the windows if used for a long time. When fog exists on the window, please choose defrosting mode.

Outer circulation mode



In this mode, the outer fresh air is sent into the vehicle.

⚠ Attention: - When the vehicle is running at a high speed in an outer circulation mode, wind will enter into the vehicle. It is normal that temperature changes because of the temperature selection at that time. If not needed, it can be switched to the inner circulation to avoid this situation.

- When vehicle is parked in garage or places with poor airflow, please turn on inner circulation mode to prevent outer air from entering into vehicle, which may cause poisoning.

- The dirty air inside vehicle will cause driver to be exhausted soon and distract his attention, which may lead to traffic accidents and personal injury. Therefore please turn off inner circulation mode if it's not necessary.

Defrosting mode

The fog on vehicle window's inner side is the overheated moisture condensed on the cooler vehicle glass. If the temperature control system is used correctly, this phenomenon will be limited in maximum extent. There are two modes for clearing fog and frost on front windshield. Using defogging mode can clear fog and moisture on the window and increase inner temperature. Using defrosting mode can clear fog or frost on front windshield more quickly.



Defrosting mode: this mode can guide air flow to front windshield and side window's outer air outlets. When defogging, the A/C switch needs to be turned on. The lower the temperature is, the greater the air volume is, and the better the defogging effect will be.



Defrosting mode: this mode can guide air flow to front windshield and side window's outer air outlets.

1

2

3

4

5

6

7

8

9

10

11

12

▲ Attention:- To ensure maximum defrosting/defogging effect, when using this function, it will automatically switch to the air outer circulation and opened A/C state. If there is a specific demand, it can be closed by pressing the inner circulation button and A/C button.

- Poor vision of window will increase the possibility of traffic accidents and personal injury. Therefore, please get familiar with controlling defogging and defrosting function.

Rear window and outer rear-view mirror defogger

Your vehicle is equipped with a rear window defogger. The rear window defogger can clear fog and frost with heating strip. Before using this function, please clear the accumulated snow on rear window.



Rear window defogging: Press the button to turn on/off the rear window defogger. When the indicator on the button is on, it means the function has been activated. The function can work only when power system has started, and the heating will stop automatically after working for 20 minutes. You can press the button to turn off the function in advance.

▲ Attention:- Do not use sharp tools to scratch the inner side of rear window. Otherwise the heater strip may be cut off and damaged, and the corresponding repair and maintenance are not within warranty range. Do not stamp vehicle's plate, glue tape or other decorating paper on the defroster.

AUTO button

AUTO Press this button and the air conditioner is in full automatic control. In this mode, the air outlet mode, air volume, inner and outer circulation, compressor switch of air conditioning will be automatically adjusted, and the air outlet temperature can be adjusted according to seasonal environmental changes. You just need to set a comfortable temperature in the vehicle. It is generally recommended that the comfort temperature is 25°C.

Mode button

MODE Press it to adjust the outlet modes of A/C. The mode is switched by repeating operations in face-blow, face-blow&foot-blow, foot-blow, foot-blow and defrosting modes.

OFF button

OFF Press this button to close the blower and all function of A/C.



Outlet adjustment

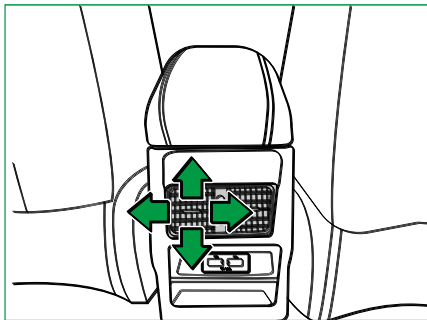
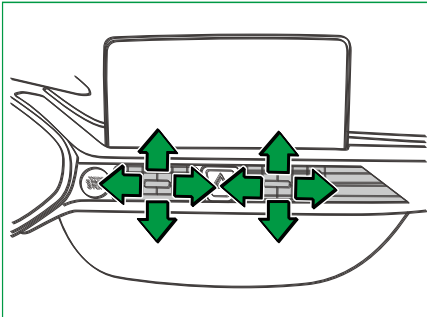

Move the central control paddle of each outlet vertically and horizontally to change

the direction of the airflow. Adjust the paddle from left to right to turn on or off this function.

Passenger compartment air filter

Your vehicle is equipped with a passenger compartment air filter. It's located in instrument panel's lower side, and can be checked or replaced by disassembling storage box.

The filter filters out most of the pollen and dust in the air that enters the vehicle. This filter needs periodic replacement.

The replacing procedures of the passenger compartment air filter are as follow:

1. Take down the storage box;
2. Disassemble the old air filter assembly;
3. Install the new air filter and reinstall the storage box in the reverse order.

Infotainment system

Please refer to vehicle's infotainment system instruction for detailed operation instructions of infotainment system.

1

2

3

4

5

6

7

8

9

10

11

12





8

Start and driving

● Run-in period	129	Parking or braking	135
● Driving precautions	129	Parking charge	136
Before entering the vehicle.....	129	● Brake	136
Before driving.....	129	Brake system	136
● Power switch.....	130	Anti-lock braking system (ABS).....	138
Power state switching.....	130	Electronic brake force distribution system (EBD)	138
One key start.....	130	Brake assist system.....	138
Emergency start.....	130	Hill-start assist control(HAC)	138
Vehicle power off.....	131	Traction control system (TCS).....	139
Emergency power off	131	Electronic stability program of body(ESP)	139
PEPS system alarm indication.....	131	Parking Brake	139
● Driving	133	● Steering	141
Start the car.....	133	Electric power steering.....	141
Driving.....	133	Emergency turn	141

Start and driving

Side slip	141	● Drive cautiously	165
● Drive Assist System	142	● Various driving situations	166
Cruise control system(CCS).....	142	Drunk driving	166
Reversing radar system	144	Quick tire leak	166
Reversing image system*	149	Night driving	167
● 360° panoramic parking system*	150	City driving.....	168
Tire pressure monitoring system	155	Driving in rainy days and slippery roads.....	168
Lane departure warning system (LDWS)*	157	Driving through deep water.....	169
Forward collision warning system (FCWS)*	159	Ramp and mountain road driving.....	169
High beam assist system(HMA)*	160	Ramp parking	170
Blind spot monitoring system*	162	Winter driving	171
Reversing assist system*	164	Highway hypnosis	171



Run-in period

During the initial period of time when a new car was on the road, the degree of wear of the various parts of the vehicle was much higher than that after running-in. The effect of this running-in process mainly depends on the driving condition of the initial 3000 km.

Here are some worthwhile experiences when driving within the initial 3000km:

- Do not press the accelerator pedal to the bottom.
- The speed should be kept within 60km/h.
- Avoid full loading and do not overload.
- Do not use new cars for pulling other vehicles.

Driving precautions

Before entering the vehicle

1. Make sure the charging cable is pulled out.
2. Make sure that the charging cover is closed (especially in rain and snow)
3. Make sure that all windows, interior and exterior mirrors, light bulbs and lights are clean and working properly.
4. Make sure that there is no liquid leakage at the bottom of the vehicle and no obstacles around it.
5. Make sure that the tire inflation pressure is normal and there is no scratch on the tread.

Note:

- If the vehicle has been put on hold for a long time. Before entering the vehicle, check whether the terminals of the lead-acid storage battery in the front cabin are connected to the power harness.

Before driving

1. Be sure to familiarize yourself with the vehicle and safe operation methods.
2. Adjust the seat to a comfortable position.
3. Adjust the car interior and exterior rear view mirror.
4. Make sure that all occupants in the car are fastened seat belts.
5. Press the power switch to power on, check the indicator light and warning light status, confirm that there is no warning light.
6. Check the power battery whether the battery is enough. Power battery meter indicates the operational battery power. Please refer to "Chapter V Instrument and Control" for details. Please judge whether the vehicle can reach the destination according to the power battery level. If the power battery is low, please charge it as soon as possible.

▲ Attention: Discharged items on the instrument panel or coat rack will obstruct the line of sight, and may also collide and hit the passengers in a sudden braking or collision to cause personal injury or damage to the vehicle. Please clear it before driving.

1

2

3

4

5

6

7

8

9

10

11

12

Start and driving

Power switch

The car is equipped with a keyless system, that is, when the smart key is in the vehicle sensing area, the driver does not need a mechanical key after entering the vehicle. The vehicle can be started by pressing the power switch on the dashboard.

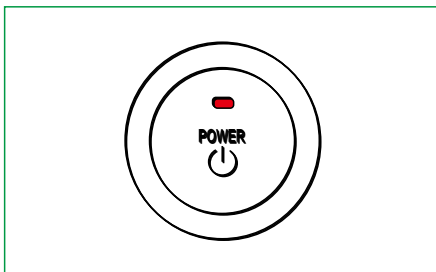

Power state switching

Carry the smart key into the vehicle; select the shift gear in the N position, and not step on the brake pedal;
— Press the switch and the power state is switched to ACC;
— Press the switch again and the power

state is switched from ACC to ON;

— Press the switch again and the power state is switched from ON to OFF, then the vehicle power is off.

Note:

- When the power state is ACC, ON, the start switch indicator is amber;
- When the selected shift position is not in the N position, the ACC cannot be turned OFF.

▲ **Attention:** - Do not put the vehicle in ACC state for a long time, otherwise it will lead to 12V lead-acid battery loss.

One key start

Carry the smart key into the vehicle, select the gear to be in the neutral position, and press the brake pedal;
- After the switch indicator turns green, press the switch and release the switch in time after startup.

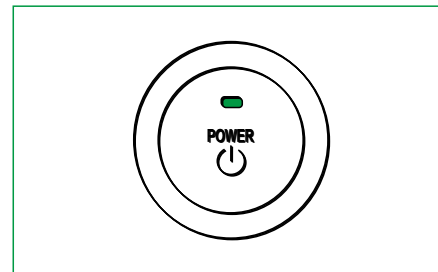

Emergency start

Select the shift gear in the N position.
Do not step on the brake pedal and press and hold the power switch for about 15 seconds to start the vehicle.



▲ Attention: One key start may not work in the following situations:

- Key is outside the vehicle;
- Smart key battery power is too low;
- There are nearby facilities that release strong electromagnetic waves, such as TV towers, power stations, radio stations, etc.;
- The smart key is in contact with or covered by a metal object;
- The smart key is placed in the corner of the vehicle.

When the smart key power is low, please use the backup antenna to start the vehicle. When the power is low, place the smart key in the cupboard of the dash panel (the first cup holder in front) and hold the brake pedal until the start switch indicator lamp turns green. Press the start switch and release the start switch immediately after startup.

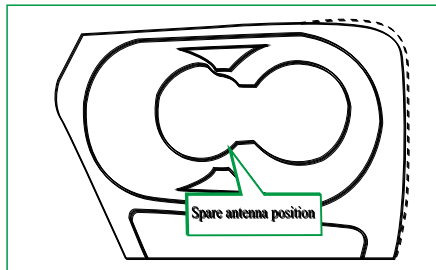

Vehicle power off

Press the power switch to power off after the car is stopped.

Emergency power off

Press the power switch 3 times continuously within 3 seconds to power off in an emergency.

Warning

- When the vehicle is running, it is not allowed to press the power switch, otherwise it will lock the steering wheel, causing a crash and serious injury.

PEPS system alarm indication

About the operation of PEPS system, you can check the relevant prompts in the instrument.

Key was forgotten inside the vehicle

It reminds the driver that there is still a key in the car when the vehicle is locked. Take the key out of the vehicle. If the key is not taken out of the vehicle, the vehicle can be locked by pressing the lock button on the other key, but the keyless entry function cannot be used at this time.

Turn power switch off before leaving the vehicle

It reminds the driver to check that the vehicle is not turned off. Please turn off the power and leave the vehicle.

Key outside the vehicle

It reminds the driver that the key has been taken out of the vehicle. Please retrieve the key. Otherwise, the normal operation

1

2

3

4

5

6

7

8

9

10

11

12

of the vehicle will be affected.

Key unidentified

It reminds the driver the key is not found; please check the key position and place the key in a place where it is not shielded.

Key low power warning

It reminds the driver that the key battery power is low; please change the battery.

ESCL (Electronic steering column lock) is not unlocked. Please turn the steering wheel and try again

It reminds the driver that the ESCL latch is stuck and not unlocked. Please turn the steering wheel slightly and then press the start button again. The steering wheel lock can only be released.

Please press brake pedal to start

To remind the driver that he wants to start the vehicle, he must first depress the brake pedal, and then press the start button to start the vehicle.

ESCL is not on lock, please turn the steering wheel

When the power supply is turned off, the car is closed to open.

If ESCL is not locked, an alarm will be given. The possible cause is that the lock tongue is stuck and not popped when the lock is locked. At this point, the driver needs to turn the steering wheel to ensure that the ESCL is locked.

ESCL unlocked failure, please press start button

It reminds the driver that the current ESCL is not unlocked and the steering wheel cannot be turned. To unlock the lock, press the start switch again to trigger the ESCL unlock.

ESCL restriction can also start "N" times, please check and repair at 4S store in time

In the previous driving cycle, there was an unusual wheel speed.

The PEPS system will record the fault. When the power state is switched to ACC, the driver is prompted for the remaining number of starts. Please timely go to the 4S shop to check the status of the wheel speed signal and ESC and repair it.

Please timely repair ESCL fault to 4S shop

It reminds the driver that there is something wrong with the ESCL or the ESCL harness connection.

It is necessary to go to the 4S shop for inspection and maintenance in time.



Driving

Start the car

- When the brake pedal is not pressed, the power switch is pressed once and the vehicle is placed in the ON position. The indicator light of the instrument and some of the indicators that need to be self-checked turn on, and the low voltage and high voltage of the vehicle are connected.
- Step on the brake pedal, press on the electric switch, the instrument ready light lit, the vehicle is into the driving state.

Warning

- Do not press the power switch continuously.

Note:

- If you press the brake pedal and press the power switch but the READY indicator is not on, please restart.
- Before driving, please check the instrument power battery meter or check the reference remaining mileage displayed on the MP5 to confirm whether the power battery can meet the driving demand. If the battery power is insufficient, please charge it in time.

Driving

1. Depress the brake pedal and remain motionless, shift gear from N to D; the instrument and the MP5 shows "D".
2. Put down the parking switch.
3. Release the brake pedal, the vehicle began to creep; light accelerator pedal, the vehicle began to travel.
4. If accelerating, gradually depress the accelerator pedal; if uniform speeding, maintain the accelerator pedal to a certain degree of opening.
5. If braking, depress the brake pedal.
6. If the reversing, depress the brake pedal until the vehicle parked and remain stationary; shift gear to R; release the brake pedal, the vehicle began to creep, light accelerator pedal, the vehicle began to reverse.
7. If ECO mode needs to be used, You can turn on the ECO mode through the central control screen "Vehicle Settings>Car Settings>ECO". "DE" will be displayed on the instrument and MP5. At this

1

2

3

4

5

6

7

8

9

10

11

12

moment, the accelerator pedal can be used to accelerate, decelerate, slide and recover energy. When in acceleration, the accelerator pedal is required to a certain degree of opening; when slow down the speed, slowly release the accelerator pedal, the smaller the pedal opening, the deceleration is stronger, and the vehicle will have greater energy recovery. When in emergency braking, you still need to depress the brake pedal.

Warning

- Do not driving vehicle after drinking alcohol.
- Accidental vehicle movement may result in serious injury.
- When in the shift process, do not step on the accelerator pedal or step on the accelerator pedal process to prevent the shift, to prevent the vehicle out of control.
- When shifting or parking, please observe the display of information on the meter or MP5, to confirm whether you are the desired position.
- Please don't press brake pedal and accelerator pedal at the same time.
- Emergency braking should be avoided in the course of vehicle driving.
- The vehicle should be slowed down as much as possible during the turn and no sharp turns.
- For safety reasons, don't climb steep slopes.
- When the vehicle is in the ready state and block position in D or R position, be sure to step on the brake pedal or pull up

the parking switch, otherwise the vehicle will creep line; If you leave the vehicle, be sure to pull the car handle and put the gear position in N gear.

- For ramp parking, do not step on the accelerator pedal to stop the car, you can step on the brake pedal or pull the EPB.
- The vehicle has the active safe ramp to start the auxiliary function, when the vehicle uphill, loosens the acceleration pedal vehicle to stop automatically in the ramp, then treads the acceleration pedal vehicle to start for the smooth driving.
- Avoid vehicles involved in deep water driving; if it needs to pass through the water surface, wading depth must not exceed the bottom edge of the car with low-speed driving.
- Do not open the front cover when the vehicle is in a rainy condition.
- In vehicle driving process, if the bottom of the car serious scratches, please contact JAC authorized after-sales service store.

**Note:**

- The vehicle has a creep function, that is, when the vehicle is in the READY state, the gear is in the D range or the R range, the brake pedal is released, the parking brake is released, and the vehicle creeps when the accelerator pedal is not depressed.
- During vehicle start-up or driving, the vacuum pump in the front cabin will work intermittently and the vacuum pump will emit a "buzzing" sound. It is normal.
- Frequent rapid acceleration of vehicles may reduce the vehicle power performance, which is a normal phenomenon.
- Drive carefully on projection road surface or a fixed limit block place.
- During driving, please charge as soon as possible if the meter's power battery (SOC) is less than 15%, the charging status indicator  is on, and the remaining mileage is about 20km. If the battery power (SOC) is less than 10%, the battery power meter displays "-", and power battery is about to run out, you must charge as soon as possible.

- The car has a standard mode and ECO mode; in ECO mode, the accelerator pedal control vehicle acceleration, deceleration, taxiing and energy recovery. When in acceleration, the accelerator pedal is required to a certain degree of opening; when slow down the speed, slowly release the accelerator pedal, the smaller the pedal opening, the deceleration is stronger, and the vehicle will have greater energy recovery. When in emergency braking, you still need to depress the brake pedal.

Parking or braking

1. Park the vehicle on the right road.
2. Depress the brake pedal until the vehicle stops slowly, and remain motionless.
3. Pull up the parking handle (EPB switch).
4. Put the gear position in N.
5. Release the brake pedal.
6. Press the power switch to power off.
7. If it needs to be charged after parking, please refer to "Chapter III Charging"

 Warning

- Improper parking can result in serious injury.
- When parking or stopping, be sure to put the gear in N position and pull the parking switch to prevent the vehicle from moving accidentally.
- Never leave children or people with mobility problems in the car. They may release the parking or EPB switch, operate the shift lever, cause the vehicle to move, cause an accident and cause serious injury.

1

2

3

4

5

6

7

8

9

10

11

12

▲ Attention: Parking carefully in the place with fixing stopper or blocks, otherwise the vehicle bumpers and other parts may be damaged. In order to avoid damage to the car, please park the car before the wheels touching those stoppers.

Note:

- Take the key when you leave the car.

Parking charge

When you arrive at the destination, it is recommended to immediately charge, see "Chapter III Charging" for details.

1. Please power off the vehicle, open the charging port cover and charging socket cover.
2. Use the charging cable to connect the vehicle and charging power supply.
3. After the charging cable is connected, the vehicle will emit a "beep" sound, the charging indicator will turn yellow, and the charging cable is connected normally; then the "beep-beep" sound will be heard twice, the charging indicator will change from yellow to green, charging begins.
4. After power battery is full, the charging indicator flashes off.

Brake

Brake system

The vehicle brake adopts a dual-circuit hydraulic braking system. If one braking circuit fails, the other circuit can still brake, but the braking distance will increase. The vehicle braking system also has an energy recovery function. When energy is recovered and the vehicle is in D block, when coasting or braking, kinetic energy is converted into electrical energy, which is charged into the power battery to recover energy and improve the driving range of the vehicle. When decelerating and stopping, it is achieved by pressing the brake pedal. Energy recovery only plays an auxiliary role.

 **Warning**

- The vehicle is driving on a slippery road and it must be carefully braked or accelerated. If you suddenly accelerate or brake, it may cause the wheel to slip and cause an accident.



▲ Attention: - If the brake pedal stroke or pedal force increases, indicating that the brake system may need to be repaired, contact an authorized JAC dealer.

- Do not put your foot on the brake pedal while driving, otherwise it can cause brake components to wear, overheat, extend the braking distance, reduce safety, and reduce the vehicle's driving range.

- Keep a safe distance from other vehicles while driving and avoid rear-end collisions.

- After a car washing, wading, or winter brake icing, the braking distance increases, making it particularly dangerous at high speeds. When the brake is wet, please lower the speed and intermittently lightly step on the brake pedal. The brake heats up to accelerate the evaporation of water until it returns to normal.

- When driving on a longer steep slope, over brake temporarily overheats the brake.

- When the vehicle passes through low-lying roads, it may be normal for the brake pedal to be hardened.

- When driving on salt (for thawing), if the brake pedal is not depressed for a long time, the

braking effect will be delayed. Please clear the salt layer on the brake.

- The braking distance will vary depending on the road (tar or sand road), road conditions (wet, dry, icy), tire tread, brake condition, vehicle weight, and braking force, so it is very important to keep a sufficient distance with other vehicles.

- Do not brake frequently, otherwise the brakes will overheat and will not cool in time, speeding up wear.

- When the vehicle turns, the cruise speed decreases, and if the turns are too large, the cruise is withdrawn directly.

Brake friction plates and other systems are automatically monitored. When the relevant indicator/alarm light is on or text message appears, check the reason immediately. You can ask JAC authorized after-sales service store for additional information. The distance between brake disc and brake friction plate is about 0.15-0.4 mm.

The following table lists the values of brake pedal travel. These values act as reference values. Details of the adjustment and other possible values can be obtained from JAC authorized after-sales service store.

Item	Unit	Parameter
Total travel of brake pedal	mm	126
Free travel of brake pedal	mm	3-8

1

2

3

4

5

6

7

8

9

10

11

12

Anti-lock braking system (ABS)

The role of ABS is to avoid wheel locking during emergency braking or braking on wet roads, helping the driver to maintain steering control and prevent the vehicle from slipping or running.

▲ Attention: The ABS does not change the time it takes for the brakes to engage, nor does it necessarily shorten the braking distance.

Even with ABS, the vehicle sufficient braking distance must be set.

- Do not use point brake otherwise it will reduce the braking effect and extend the braking distance.

Note:

- Start the vehicle and the ABS fault warning light on the instrument illuminates the self-test. In the event of a malfunction, the ABS fault warning light will remain on and the ABS system will be turned off. At this time, the brake of vehicle still exists. Please contact the JAC authorized after-sales service store in time.
- When the ABS is in operation, the driver feels brake pedal vibration and hears the vibration of the brake, which is normal.
- In case of emergency braking, the brake pedal is pressed to the end and kept in order to obtain the best braking effect.

Electronic brake force distribution system (EBD)

When the vehicle is braking, EBD automatically adjusts braking force distribution proportion of front and rear shafts to improve the braking efficiency and matches with ABS to improve the braking stability, thus ensuring the stability of vehicle.

Brake assist system

The brake assist system can identify the situation when the driver quickly presses the brake pedal but the press force is insufficient, and increase the brake force through ESP's active pressurization.

Hill-start assist control(HAC)

HAC is a function developed on the basis of ESP, which is mainly used to prevent the car from slipping during hill-start.

The main working process of HAC can be divided into the following stages:

- (1) The driver steps on the brake pedal to stop the vehicle and keep it still;
- (2) The driver releases the brake pedal and steps on the acceleration pedal for hill-start;



- (3) ESP maintains the brake pressure (for about 3s) to prevent the vehicle from slipping backwards during the period from releasing the brake pedal to stepping on the acceleration pedal;
- (4) When the vehicle starts, the brake pressure is released.

Traction control system (TCS)

When TCS detects that the speed of the driven wheel is lower than that of the driving wheel through electronic sensors, a signal will be sent out to control the driving torque of the vehicle or brake the wheels, so that the wheels stop slip. TCS can not only improve the vehicle driving stability, but also enhance the acceleration performance and the ability to climb.

Electronic stability program of body(ESP)

When the wheels slip, or the vehicle heels or tires lose the adhesion, ESP will immediately get involved in reducing the speed of drive motor and conducting brake control for individual wheel on purpose, and finally put the car into the normal orbit to avoid the risk of vehicle due to out of control.

▲Attention: - ESP function works automatically. It is not recommended to manually turn off ESP. Otherwise, driving the vehicle without stability control function may lead to collision and cause personal injury and damage to your car or other property.

- The ESP function can be temporarily turned off only when the vehicle is stuck in mud, swamp, etc., and needs a trailer or when it skids. After these situations, it is recommended to turn on the ESP function again.

Parking Brake

Electronic parking braking (EPB)

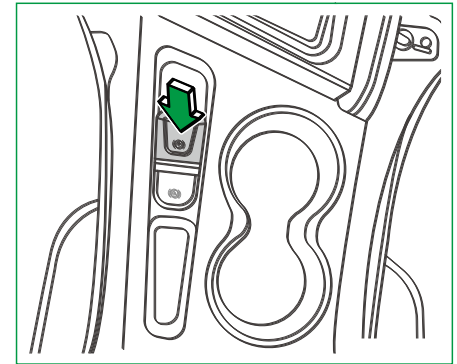

When parking, press the EPB button, the parking status indicator "(!)" lights up. Release the electronic parking brake. Turn on the power switch and place it on the "ON" gear. Hold the brake pedal and press the electronic parking button. The indicator lights and the parking status indicator "(!)" of the instrument cluster both go out, indicating that the electronic parking is released.

1

2

3

4

5

6

7

8

9

10

11

12

▲ Attention: - Before driving, make sure the parking is completely released. If the brake pedal fails or an emergency occurs, the EPB button can be pulled to brake the rear wheel.

Electronic parking brake auto-off function

The electronic parking auto-off function means when the vehicle starts, if the output power of the motor is sufficient, the system automatically turns off the electronic parking and the vehicle runs immediately. The electronic parking auto-off function makes it easy for the vehicle to start on the slope and prevent the vehicle from slipping.

Conditions for using the parking brake auto-off function:

- Driver side door is closed
- Driver safety belt is fastened
- The vehicle is in READY state
- The vehicle is in D gear
- Press the accelerator pedal and the power of the vehicle guarantees that no slipping will occur at this time

▲ Attention: - In the "READY" state of the vehicle, the shift lever is set to D or R, the brake pedal is released, and the vehicle will creep.

- When the 12V lead-acid battery is low, the electronic parking cannot be turned off. Please use jump start. For details, see "Chapter IX Emergency Response."
- When the electronic parking is turned on and off, the rear caliper will be clamped or released and noise may be generated. This is normal and it is not a fault in the system.
- Never use the front area of the parking brake button as a glove box to prevent small objects such as coins from catching or damaging the buttons.
- The electronic parking auto-off function cannot exceed the physical limit of road attachment, and special caution is required on wet roads.
- The electronic parking auto-off function does not replace the driver's attention.

Note:

- When parking on a flat road, if you forget to park your car, the vehicle will automatically park after you open the main drive door or the vehicle is powered off.



Auto hold function

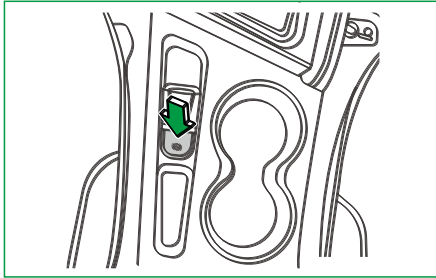

The auto hold function, that is, when the vehicle is in a stationary state, does not need to continuously stop the brake pedal, and the system automatically stops the car to prevent the car from slipping.

Press the AUTO HOLD switch to turn on the auto parking function. The indicator light on the switch lights up. Press AUTO HOLD switch again, the indicator light on the switch goes out and the vehicle exits the automatic parking function.

Conditions for starting AUTO HOLD function:

When the brake pedal is depressed to decelerate the vehicle to a standstill, the vehicle is parked for 2 seconds and parked automatically.

Steering

Electric power steering

It can provide steering assistance for the driver.

- ▲ **Attention:** - When driving or parking, continuous steering will reduce the assist and the steering will become heavier. When steering system temperature returns to normal, the steering force will return to normal.
- When turning too fast or when using it frequently, it is normal for the system to sound a tone to avoid overheating of the steering system.
- The electric power steering system fault warning light is on, indicating that the electric power steering system has failed and the steering may become heavy. Contact JAC authorized after-sales service store.

Emergency turn

In emergency situations, if there is not enough braking space, steering is more effective than braking energy to avoid people or obstacles.

Hold the steering wheel at the 9 o'clock and 3 o'clock positions to quickly turn the steering wheel, avoiding obstacles and returning immediately. This kind of emergency may occur at any time. Be careful to drive and fasten your seat belts.

Side slip

The vehicle may get out of control when sliding. The prudent driver will take appropriate measures according to the existing driving conditions and avoid speeding according to the driving conditions, thus avoiding most of the side slip. However, slip can occur at any time. There are three types of side-sliding methods and corresponding vehicle handling methods:

1

2

3

4

5

6

7

8

9

10

11

12

Start and driving

1. The brake slip sideways and the wheels will lock. Your vehicle is equipped with ABS that helps you avoid wheel locks.
2. When the steering or turning aside, the speed is too fast or the steering is over steering, causing the wheels to slip and lose steering force. Releasing the accelerator pedal is the best way to handle a side slip.
3. Acceleration side slipping. Accelerating too fast causes the drive wheel to slip. Releasing the accelerator pedal is the best way to handle the accelerated side slip.

▲ Attention: - Adhesion will decrease if there is water, ice, snow, sand or other debris on the road surface. To ensure safety, lower your speed.

- When driving on a slippery surface, avoid sudden steering, acceleration or braking.

Drive Assist System Cruise control system(CCS)



The cruise control system makes it possible to store and maintain any speed ranging from 40km/h to 160km/h. When driving uphill or downhill, it may deviate from the stored speed.

If road conditions do not allow for a fixed speed, please do not use cruise control. Refer to "Alarm lamp and indicator" for a description of the cruise indicator.

Note:

- There may be some deviation between the current control speed and the actual speed displayed by the cruise control system.
- The performance of the cruise control system on a ramp depends on the speed, the load, and the slope of the road. When climbing a steep hill, you may need to step on the acceleration pedal to maintain speed. When going downhill, you may need to brake or drop to a low gear to maintain speed. When the brake is activated, the cruise control is closed.

Start CCS

1. Press the button  on multi-function steering wheel to light on the cruise indicator  (white) on the combination instrument.

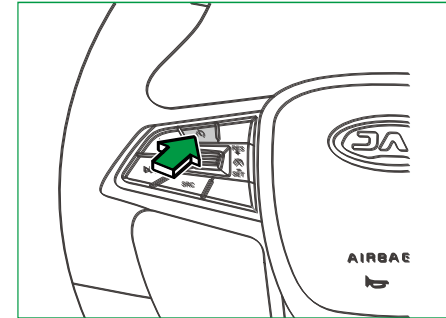



2. Accelerate to the required speed (when the speed is > 40km/h), rotate the roller in "SET/-" direction, the current speed will be stored and the vehicle will be kept at this speed. The indicator  (green) on combination instrument will be lighted, and the acceleration pedal could be released at this time. Depressing the accelerator pedal increases the speed of the vehicle. After the acceleration pedal is released, the speed will be turned to the original stored state.

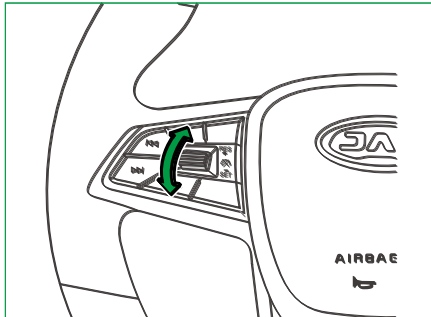

Increase the set speed of cruise control

You can perform any of the following procedures:

1. Rotate the roller in "RES/+ " direction and hold it. The vehicle will accelerate gradually and you can release the button when the vehicle reaches at the desired speed.
2. Shortly and repeatedly rotate the roller in "RES/+ " direction. Each time you rotate the roller in this way, the cruise speed increases by 1.0km/h.
3. Step on the acceleration pedal to accelerate the vehicle to the desired speed, and then rotate the roller in "SET/-" direction to set a new speed.

Reduce the set speed of cruise control

You can perform any of the following procedures:

1. Rotate the roller in "SET/-" direction and hold it. The vehicle will decelerate gradually and you can release the roller when the vehicle reaches at the desired speed.

2. Shortly and repeatedly rotate the roller in "SET/-" direction. Each time you rotate the roller in this way, the cruise speed decreases by 1.0km/h.
3. Step on the brake pedal to decelerate the vehicle to the desired speed (when the speed is > 40km/h), and press the button SET/- to set a new speed.

Release the cruise speed control

You can perform any of the following procedures:

1. Step on the brake pedal or the clutch pedal.
2. Press the middle wheel button  to cancel the cruise control.

In any of the above operations, the green indicator  on the cruise control combination instrument can be turned to white, but the system will not be turned off.

1

2

3

4

5

6

7

8

9

10

11

12

Resume cruise control

You can perform the following procedures:

When the speed set is removed, the cruise control system has not been turned off.

When the speed is no less than 40km/h, rotate the roller in "RES/+" direction, the speed will be automatically restored to the set speed before lifting, and the green indicator  on the combination instrument will be lighted again.

Clear cruise control memory:

Press the button  on the steering wheel to turn off cruise control system and cancel the previously set speed. The indicator on the combination instrument will be extinguished.

Reversing radar system

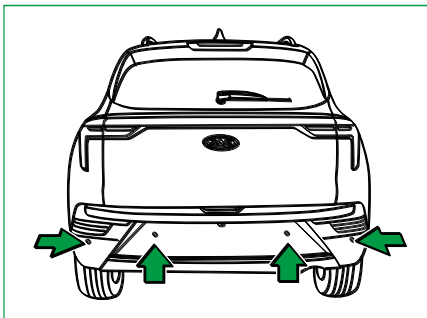

The reversing radar system is based on the principle of ultrasonic distance measurement of the radar sensor to determine whether there are obstacles before and behind the vehicle, and to indicate the distance to the nearest obstacle.

Warning

- The reversing radar system can not replace the driver's judgment to outside situations and the driver still needs to concentrate on parking or similar operations. Please keep observation on the surroundings all the time.
- Because of the blind zone of reversing radar sensors, please pay special attention to children and animals. The sensors can not detect them on any occasions which may result in the risk of accidents!
- The reversing radar system only provides auxiliary function and can not predict or avoid obstacles, so you must not lower your guard because of this system.
- Reversing radar system may be affected by many environmental factors and conditions, resulting in that the system can not properly identify objects and people.



Methods

On: When the power is on, you can start the reversing radar system by shifting into reverse gear.

Off: Turn off the reversing radar system by removing the reverse gear.

System self-test and warning types

At the start of the operation, the reversing radar will conduct a quick self-test of the entire system to ensure that the components are working correctly. The self-test results are shown in the table below:

Self-test result	Buzzer
Normal	Beep once
System fault	Beep twice

In normal operation, the controller sends pulse signals of different frequencies to the buzzer according to the different segments where the detected obstacle is located, and the buzzer sends out calls of different frequencies according to different distance ranges to indicate the distance of the obstacle.

Obstacle distance	Voice reminder	Area	Attention
1.0m~1.5m	Slow	Safe place	Normal parking
0.6m~1.0m	Fast	Warning area	Slow down to park
0.35m~0.6m	Rapid	Dangerous area	Slow down to park
0~0.35m	Long buzzing	Dangerous area	Stop to park

▲ Attention: - If the sensor is covered by foreign matters (such as snow, rain, dust, mud, etc.), the system may not work.

- When the vehicle is traveling on rough roads such as forests, gravel roads, zigzag roads and slopes, the reversing radar system may fail.

- When there are large interferences at the detecting range of the sensor (such as daylight lamp radiation, vehicle loudspeaker, metal noise, etc.), the system may fail.

- Do not push or scratch on sensor's surface, or you will damage the overburden of sensor.

- The sensor system may not recognize the cloth or sponge that can absorb the frequencies.

- If necessary, clean the dirty surface of sensor with soft sponge and clear water.

- If the bumper height of vehicle or the installment of sensor is changed, the performance of reverse radar system will be influenced.

Start and driving

▲ Attention: - The system can only detect the sensor position and objects within the range.

- When sensing two or more objects at the same time, first identify the nearest one.
- The accident or damage to the vehicle due to the breakdown of the reversing radar system is not covered by the warranty, so it is necessary to confirm the condition behind the vehicle before reversing.

Warning

- It is prohibited to use high pressure water to clean the vehicle sensor.
- It is forbidden to scratch on surface of sensor with sharp objects.
- The reversing radar system is only the assistant system, so that the driver must observe the back of vehicle carefully before reversing.
- The sensor has a blind spot where it cannot detect the object. Please pay special attention to young children and pets, because the sensors cannot detect them in all circumstances and there is a risk of accidents!

Warning

- The reversing radar system cannot replace the driver's judgment to the outside. Reversing or similar operations still requires the driver to concentrate. Please always observe the surroundings of the vehicle.
- With the reversing of the vehicle, an illusion may occur: the low obstacles that have been warned disappear from the detection range of the system. Therefore, the system will no longer issue warnings. Sometimes the system cannot detect certain objects, such as chains, trailer tow bars, small painted vertical bars or fences, etc. . So if you do not pay attention, there will be a risk of accidents.



System operation

If the system cannot work normally

Please take care of the following conditions in which the reversing radar sensor may not trigger an alarm or have an alarm mistake:

Conditions that the obstacles can not be detected

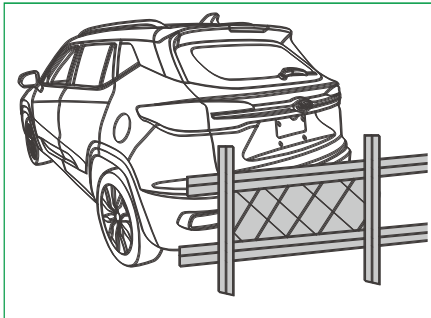

The reversing radar sensor can not detect iron wire, cable, block net and other nets.

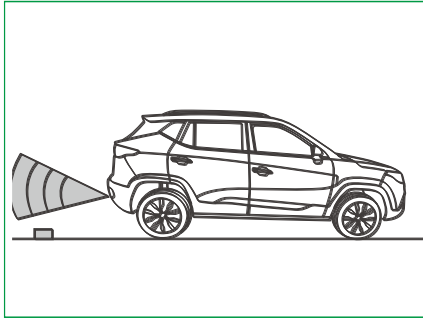

The reversing radar sensor can not detect rock, wood block and other short objects.

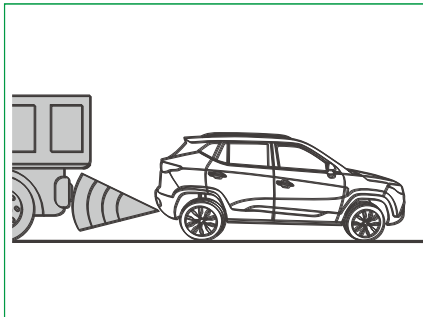

The reversing radar sensor can not detect the vehicle with a high chassis.

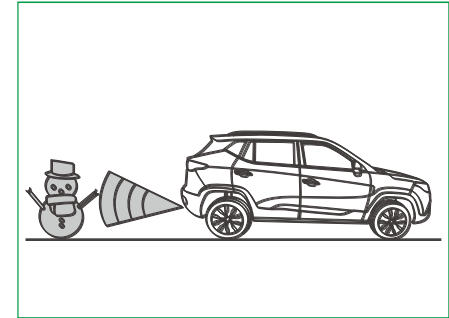

The reversing radar sensor can not detect soft snow, cotton, sponge and other objects that absorb ultrasonic easily.

1

2

3

4

5

6

7

8

9

10

11

12

Start and driving

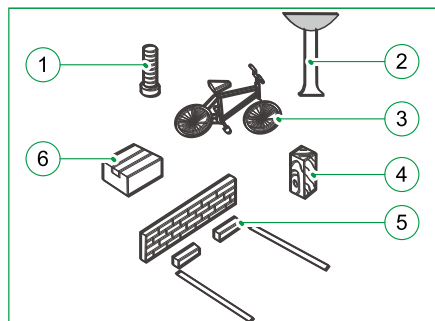

The reversing radar sensor may not detect some obstacles in special shapes.

1. Column
2. Small tree
3. Bicycle
4. Angle section
5. Cornerstone
6. Corrugated paper

Possible conditions of alarm mistakes

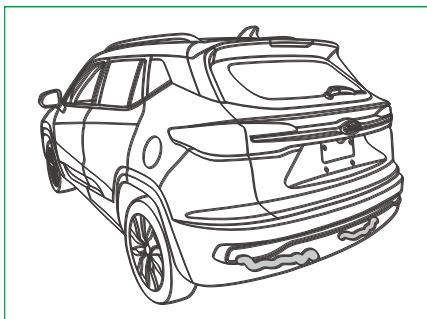

If the reversing radar sensor is frozen, the reversing radar system may have a failure in alarm.

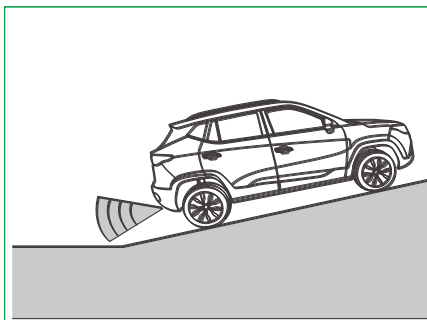

If the vehicle is on a steep slope, the reversing radar system may have a failure in alarm.

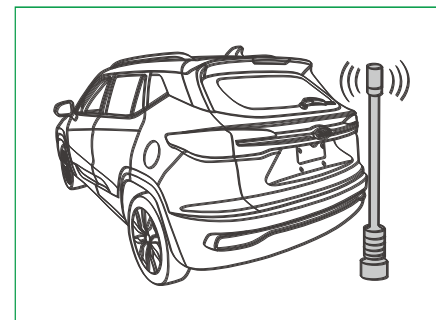

If the vehicle is equipped with a high-frequency radio or antenna, or if there is a high-frequency radio or antenna being used nearby, the reversing radar system may have a failure in alarm.

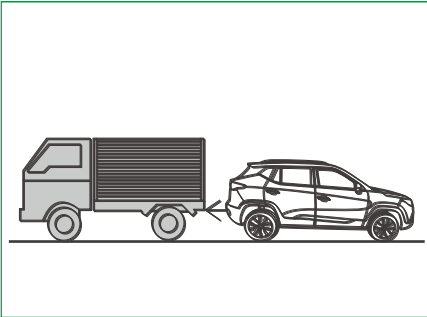

If the noises from other vehicles' horns, engines, exhausts and others get too close to the reversing radar sensor, the reversing radar system may have a failure in alarm.



When you are driving in snow or rain, the reversing radar system may have a failure in alarm.

Please contact the JAC authorized after-sales service store for maintenance when you make sure that your problem is not anyone of the above problems.

⚠ Attention: - When there are several obstacles, the reversing radar sensor only detect the nearest obstacle. When the vehicle is moving, please notice if the reversing radar sensor in other side has detected other obstacles.

- Please do not spray with high-pressure water as water gun, nor is the surface of reversing radar sensor squeezed or shocked with other methods. Otherwise, it may cause failure.

Reversing image system*

On

When the power is on, the multimedia display screen shows the image of reversing when you shift into reverse gear.

Off

If the gear is not in reverse, the reversing image function will be turned off.

⚠ Attention: - The reversing image system is only an auxiliary system. Before reversing and in the process of reversing, it is necessary to confirm the surrounding conditions, and pay attention to safety in the process of reversing, because there is a blind area that cannot be observed through the camera.

- Keep the camera surface clean at all times, for the camera covered with debris may not display the image properly.

- The system works only for assistance reverse. The reverse assistant lines are only the assistant lines for reference, because the dead angles cannot be caught by the camera, so the driver has the responsibility to pay attention to the area behind the vehicle before and during reversing.

1

2

3

4

5

6

7

8

9

10

11

12



Warning

- It is prohibited to use high pressure water to clean the vehicle sensor.
- It is forbidden to scratch on surface of sensor with sharp objects.

360° panoramic parking system*

4 wide-angle cameras, installed around the vehicle, can cover all visual angle ranges. Multi-channel images, collected by these cameras at the same time, are seamlessly spliced so that the 360° panoramic body top view is showed on panoramic images and is finally displayed on dashboard screen, which can thoroughly eliminate the visual blind zone surrounding the vehicle. It allows the driver to monitor the front, rear, left and right video pictures of the vehicle in real time and avoid accidents.

Enter the panoramic image interface

1. When the shift lever is put into the reverse gear (R), the screen image can be directly changed into the rear view.
2. Touch the "360° panorama" switch on the multimedia display screen, the screen will be changed into the split front-view image.

Exit the panoramic image interface

1. When the reverse gear (R) is exited, the panoramic parking system does not exit, and when the speed is over 15km/h and the duration is longer than 3s, the display screen is withdrawn.
2. Click the left return button on display screen to exit the display screen.



2D display interface

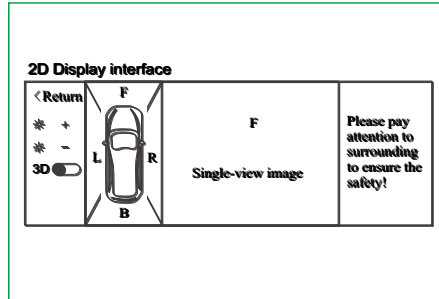

Front-view screen display (in the split screen mode, the left side is the panorama screen, and the right side is the single-channel front video image plus static auxiliary line).

Rear-view screen display (in the split screen mode, the left side is the panorama screen, and the right side is the single-channel rear video image plus static auxiliary line for reversing).

Left-view screen display (in the split screen mode, the left side is the panorama screen, and the right side is the single-channel left

video image).

Right-view screen display (in the split screen mode, the left side is the panorama screen, and the right side is the single-channel right video image)

2D display interface switch

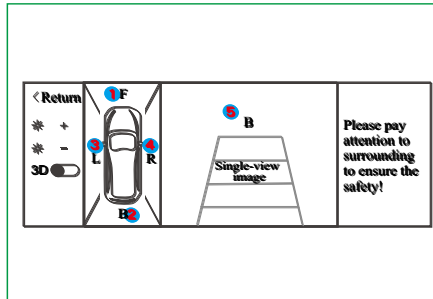

When the display interface is split, the panoramic screen is on the left side and the single-channel video display is on the right side, you can press area 1 to switch to the "front-view screen display".

When the display interface is split, the panoramic screen is on the left side and the

single-channel video display is on the right side, it can be switched to the "rear-view screen display" above by pressing area 2 or selecting the R gear.

When the display interface is split, the panoramic screen is on the left side and the single-channel video display is on the right side, you can press area 3 or pull the left turn switch when it is not in reverse gear, to switch to the "left-view screen display" above.

When the display interface is split, the panoramic screen is on the left side and the single-channel video display is on the right side, you can press area 4 or pull the right turn switch when it is not in reverse gear, to switch to the "right-view screen display" above.

1

2

3

4

5

6

7

8

9

10

11

12

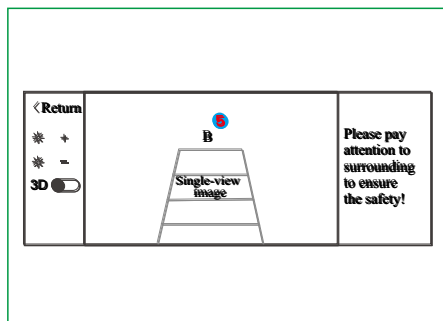

When the display interface is split, the panoramic screen is on the left side and the single-channel video display is on the right side, you can switch the displayed screen to fullscreen mode of current single-channel video display by pressing area 5; click the video display area in fullscreen mode, it will return back to split screen display mode.

2D/3D display screen switch

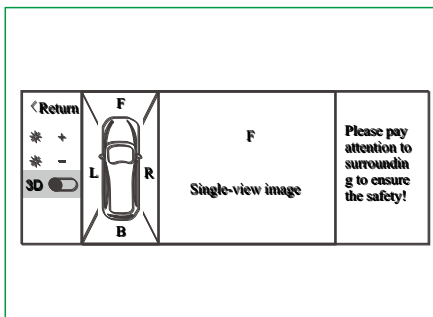

When the display interface is split, the panoramic screen is on the left side and the single-channel video display is on the right side, you can press the button "2D/3D" to switch to a 3D display screen: the left side is a 3D video display, and the right side is a single-channel video display. Click the button "2D/3D" again and the interface switches back to the previous 2D display screen.

3D display interface

In the split screen mode, the left side is a 3D panoramic screen, and the right side is a single-channel video image.

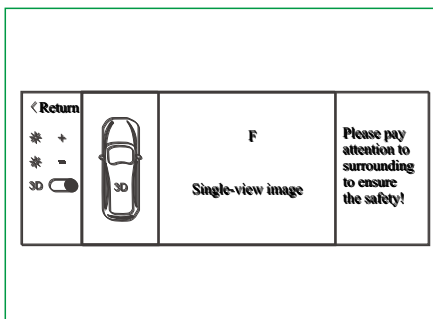



3D display interface switch

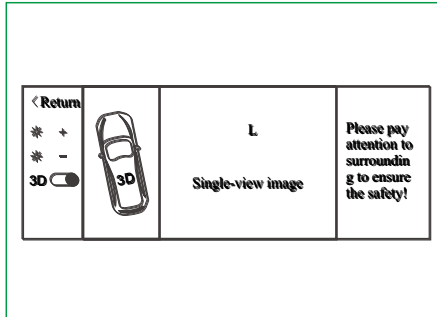

When the 3D panoramic display is shown, pull the left turn switch to change to the left-view 3D panoramic display and the single-channel left video image. When the left turn switch signal exits, the screen returns to the previous 3D panoramic display.

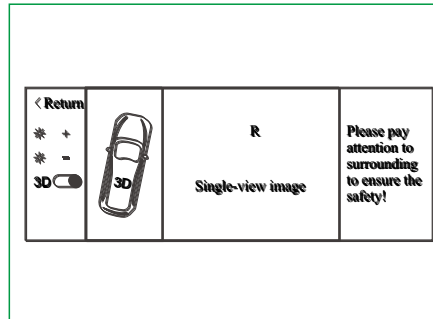

When the 3D panoramic display is shown, pull the right turn switch to switch the screen to the right-view 3D panoramic display and the single-channel right video image. When the right turn switch signal exits, the screen returns to the previous 3D panoramic display.

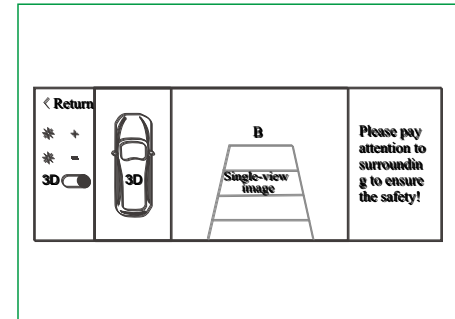

When the 3D panoramic display is shown and the shift lever is shifted into the reverse gear, the screen switches to the rear-view 3D panoramic display and the single-channel rear video image plus static auxiliary line for reversing, and the whole vehicle moves forward. When the reverse gear is removed, the screen returns to the previous 3D panoramic display.

1

2

3

4

5

6

7

8

9

10

11

12

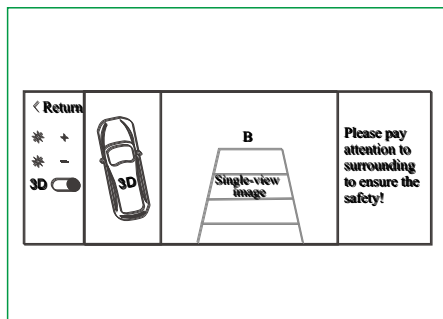

When the 3D panoramic display is shown and the shift lever is shifted into the reverse gear, pull the left turn switch to switch the screen to the left-rear view 3D panoramic display and the single-channel rear video image plus static auxiliary line for reversing, and the whole vehicle moves forward. When the reverse gear is removed, the screen returns to the previous 3D panoramic display.

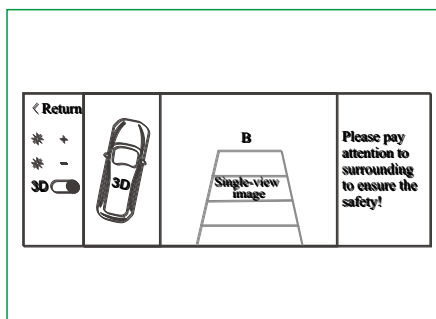

When the 3D panoramic display is shown and the shift lever is shifted into the reverse gear, pull the right turn switch to switch the screen to the right-rear view 3D panoramic display and the single-channel rear video image plus static auxiliary line for reversing, and the whole vehicle moves forward. When the reverse gear is removed, the screen returns to the previous 3D panoramic display.

360° panoramic image left and right steering linkage function

The 360° panoramic image left and right steering linkage function is an assisted driving function that can automatically turn on the 360° panoramic image when the vehicle turns on the left/right turn signal. This function can be turned on and off through the "Vehicle Setting-Driving assistance" in MP5.

There are two modes: "AVM Low speed steering" and "AVM High speed steering". After turning on the "AVM Low speed steering" mode, when the vehicle speed is below 20km/h, the 360° panoramic image will be automatically turned on when the left and right turn signals are turned on. After turning on the "AVM High speed steering" mode, the 360° panoramic image will be automatically turned on when the vehicle turns on the left and right turn signals at any speed.



Note:

- Although the system can provide the driver with a view of 360 degrees around the body when the vehicle is being parked, the driver still needs to observe the surrounding environment, so as to avoid that some obstacles that can not be identified by the system affect the driving safety.
- Because of the low night illumination, the 360-degree panoramic parking auxiliary system, affected by light intensity, may create "noise" on the screen, which affects the surrounding image display effect. Therefore, please observe the situation around the vehicle before driving to ensure safety!

▲ Attention: - For the 360-degree panoramic parking auxiliary system is limited by itself, please pay special attention to the following cases:

1. The panoramic parking system can achieve seamless splicing of the 4-camera(front, rear, left, right) images, creating a 360 ° panoramic view around the vehicle. The objects at the seam will disappear, so make sure there is no object at the seam before driving to ensure the safety of driving!
2. It is determined by the camera installation angle, because the camera has a fixed angle of view and there is a blind area of 250mm in front of the vehicle and a blind area of 150mm behind the vehicle, and objects in the blind area (the shaded area at the white bottom) are not visible. So before driving, please confirm if there is any object in the blind area to ensure the safety of driving!

Tire pressure monitoring system

In driving, the tire pressure monitoring system can monitor the pressure and temperature in the tire, give an alarm in time when the setting value is exceeded and help the driver to grasp the condition of the tire in real time, reducing the traffic accidents caused by the tire failure and increasing the vehicle driving safety.

Tire pressure warning description

The tire pressure monitoring system sends the warning information of states of tire pressure and system by two indicators on the combination instrument:

Symbol	Indicator lamp type	Indicator type
	Abnormal tire pressure alarm	Low pressure: normally on High pressure: normally on High temperature: normally on
TPMS	Abnormal tire pressure monitoring system	Mismatched learning: twinkle System malfunction: normally on

Tire pressure and temperature display

The current state of the tire can be displayed on the multimedia screen. Click the tire pressure monitoring icon on multimedia screen to bring up the display interface.

Note: 100kpa=1bar

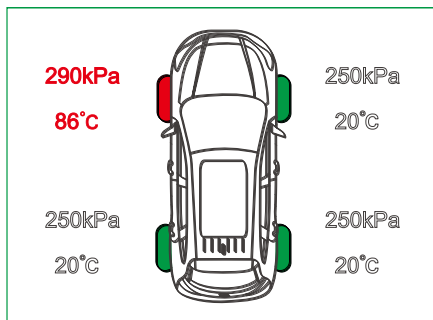

The definitions of the tire and display frame in display interface are shown as follows:

White: If the current tire pressure is approximately the same as the specified value, the corresponding tire pressure value is displayed in white, and at this time the interface indicates that the driver's tire

pressure is normal.

Red: If the current tire pressure is more or less than the specified value for more than 57.5kPa, the corresponding tire, display interface and tire pressure characters are displayed in red, and at this time the interface indicates that the driver's tire pressure is too high or too low.

If the temperature of current tire is more than about 85 °C, the corresponding tire, display interface and tire temperature characters are displayed in red, and at this time the interface indicates that the driver's tire temperature is too high.

Alarm saving function

When there is an alarm for lower pressure, higher pressure or sensor loss in driving, the system will preserve the alarm information, pressure and temperature data at the end of driving. If the power switch is closed and then opened again, the system will automatically recover to the state at end of last driving, reminding users of handling failures promptly. If the failures have been handled completely, it takes 3 minutes to drive for updating the tire pressure sensor signal.

⚠ Attention: - Although the tire pressure monitoring system helps the driver monitor the tire pressure, keeping the proper tire pressure is still the driver's responsibility.

- The standard pressure of the tire is 230kpa.

Please pay attention to the tire pressure in real time and do not charge the tire pressure too high or too low, and it should be within the range of standard pressure ± 10 kpa.

- TPMS is an auxiliary system for tire pressure monitoring. The signal's transmission is completed by the high frequency. When the high-frequency signal is interfered by the same frequency electromagnetic field for a long time, it will send a system fault alarm. When the vehicle is away from the strong magnetic field, alarm status will be automatically lifted, which is normal.

- When the vehicle is running or turning on a bumpy road, the tires are stressed differently. As a result, the tire pressure is too high or too low during this period. Sometimes the system may occasionally get an alarm. When the vehicle travels to a flat and straight road, if the pressure is normal, the alarm will be automatically released, which is normal.



1

2

3

4

5

6

7

8

9

10

11

12

Warning

- If there is an alarm indication for lower pressure, higher pressure or higher temperature, please stop timely to check and go to JAC authorized after-sales service store for maintenance as soon as possible.
- If the tire is needed to be replaced, please go to JAC authorized after-sales service store in time to relearn the tire pressure for the vehicle, otherwise TPMS will light up.
- If the TPMS lights up, there should be a failure in tire pressure monitoring system. Please go to JAC authorized after-sales service store in time for maintenance.

Lane departure warning system (LDWS)*

The lane departure warning system is designed to alert the inattentive or fatigue driver with intelligent lane departure warning. When the vehicle unintentionally deviates from the lane, the driver should be reminded to provide more reaction time and reduce the accidents caused by the vehicle deviating from the lane. The lane departure warning system is equipped with corresponding hysteresis function: the function can be activated when the vehicle speed exceeds 60 km/h, and the function exits when the vehicle speed decreases to 55 km/h.

ON/OFF

The lane departure warning function can be turned on and off by clicking the "Vehicle control-Driving assistance" lane departure system switch in the multimedia display screen.

When the system is on: The white indicator  of lane departure warning system on the instrument is on;

2. The graphic and text of the prompt information on the instrument indicate that "Auxiliary system of lane departure is on"; When the system is off:

1. The indicator  of lane departure warning system on the instrument is off;
2. The graphic and text of the prompt information on the instrument indicate that "Auxiliary system of lane departure is off";

When the system is activated:

1. The green indicator  of lane departure warning system on the instrument is on.

The system displays the working status through the indicator on the instrument. Yellow indicator is on when the system fails.

Sensitivity setting

The sensitivity of the system can be set by clicking the setting item of "Sensitivity of lane departure warning system" in the multimedia display screen of "Vehicle control-Driving assistance", including two gears: low sensitivity; high sensitivity. The system default is low sensitivity.

Warning interface

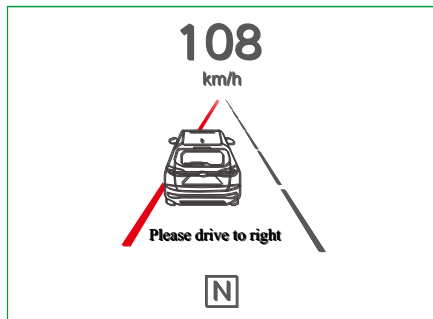

The warning interface of the combination instrument module is shown in the figure above (the vehicle deviates from the left lane line). When the vehicle deviates from the lane detected by the lane departure warning system, the combination instrument module shows the warning interface and sends lane departure warning sound, and the sound's frequency is 2 times per second.

When the lane line is not recognized after the system is activated, the lane line is gray. When the system is activated and

the lane line is identified, the lane line is lighted up on the instrument. A lane line in white indicates that the system recognizes the current lane line (right lane line, left lane line, left and right lane line). A lane line in red indicates that the vehicle has deviated from that lane line.

Warning condition

In the process of driving, if the vehicle is close to the lane line without turning on the corresponding turn lamp, there will be a risk of deviation from the lane, so that the left or right side sends an warning, reminding the driver to correct the direction.

Note:

- Under severe weather conditions such as rainstorm, the system's function will be reduced due to the influence of visual range and clarity. The driver can choose whether to enable this function according to the specific situation.

⚠ Attention: - You should not block the view of the multifunction camera (located above the front windshield) while using the vehicle. Dirt on the front windshield in the field of view will cause the system to fail to function properly. Please pay attention to wiping and cleaning!

- If the radius of the curve is too small when you are driving on the curve road, the system will not be able to give a normal warning!
- The system only provides sound and image warning, and does not actively interfere with the vehicle's track, so when the warning occurs, the user needs to judge and adjust the driving route!

- When there is severe weather such as rainstorm, snow, fog, or the lane line is not clear enough to distinguish, the system's function will be affected, resulting in the failure of normal warning!

- In the event of disassembly and installation of multi-function cameras, collision of vehicles or system function decline or abnormality, please be sure to contact JAC authorized after-sales service store for professional calibration of multi-function cameras.



Forward collision warning system (FCWS)*

The forward collision warning system detects the vehicle in front through the forward-looking camera, and judges whether the current vehicle is at risk of collision with the vehicle in front according to the distance from the vehicle in front and the relative speed of the two vehicles, and issues an alarm prompt through the instrument, reminding the driver to take measures to maintain a reasonable and safe distance from the vehicle in front. The forward collision warning system is equipped with corresponding hysteresis function: the function can be activated when the vehicle speed is no less than 10km/h.

ON/OFF

The forward collision warning function can be turned on and off by clicking the "Vehicle Control-Driving Assistance" forward collision warning system switch in the multimedia display screen.

When the system warns:

1. The red indicator  of forward collision warning system on the instrument is on;
 2. The graphic and text of the prompt information on the instrument indicate that "Collision risk, please brake".
- The system displays the working status through the indicator on the instrument. Yellow indicator is on when the system fails.

Sensitivity setting

The sensitivity of the system can be set by clicking the setting item of "Sensitivity of forward collision warning system" in the multimedia display screen of "Vehicle control-Driving assistance", including two gears: low sensitivity; high sensitivity. The system default is high sensitivity.

Warning interface

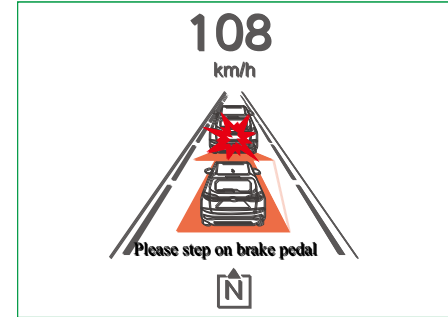

The warning lever of FCWS is divided into two levels: first level warning (common type), second level warning (enhanced type).

First level warning (common type): The first level warning adopts the indicator and graphic for prompt, accompanied by the warning sound(4 times per second) and the red indicator  that is lit.

Second level warning (enhanced type): The second level warning adopts the indicator and graphic warning for prompt, accompanied by the warning sound(8 times per second), the red indicator  is lit.

1

2

3

4

5

6

7

8

9

10

11

12

Note:

● Under severe weather conditions such as rainstorm, the system's function will be reduced due to the influence of visual range and clarity. The driver can choose whether to enable this function according to the specific situation.

▲ Attention: - You should not block the view of the multifunction camera (located above the front windshield) while using the vehicle. Dirt on the front windshield in the field of view will cause the system to fail to function properly. Please pay attention to wiping and cleaning!

- If the radius of the curve is too small when you are driving on the curve road, the system will not be able to give a normal warning!
- The system only provides sound and image warning, and does not actively interfere with the vehicle's track, so when the warning occurs, the user needs to judge and adjust the driving route!
- When there is severe weather such as rainstorm, snow, fog, or the lane line is not clear enough to distinguish, the system's function will be affected, resulting in the failure of normal warning!
- In the event of disassembly and installation of multi-function cameras, collision of vehicles or system function decline or abnormality, please be sure to contact JAC authorized after-sales service store for professional calibration of multi-function cameras.

High beam assist system(HMA)*

The high beam assist(HMA) function can be turned on or off according to traffic and environmental factors. This function can optimize the use of headlamps in driving at night. When the vehicle speed is between 40km/h and 150km/h, the system can work normally. When the vehicle speed exceeds 40km/h, the function can be activated. When the vehicle speed is reduced to 25km/h, the function will be off.

ON/OFF

The switch setting of HMA is located in the "Vehicle control-Driving assistance" in the multimedia display screen, and the system can be turned on and off by touching the "Automatic high/low beam".

System activation

After the HMA switch is turned on, the lamp combination switch should be turned on AUTO at the same time. At night, after the low beam lamp is automatically turned on, the indicator  of the high beam



assist system is lit on the instrument. When the vehicle speed reaches above 40km/h, and the conditions of low beam opening and beam suppression are not satisfied, the high beam lamp will be activated and the system will immediately suggest switching to the low beam lamp. However, the system will follow a certain delay mechanism to send out the high beam opening request. Based on this, under the premise of not interfering with other traffic participants, HMA realizes the optimized use of high beam. In addition, HMA can avoid frequent light switching, thus improving the comfort of driving.

High beam suppression request

1. The high-speed operation of the wiper or the rain sensor indicates that the ambient rainfall is very heavy and lasts for 1min, which will be judged as self-blinding. If self-blinding conditions are detected, the system will recommend using the low beam.
2. If road lighting (street lighting) is detected, the system will recommend the

use of low beam.

3. If relevant traffic conditions are detected, such as there is another vehicle traveling in the same direction or opposite direction, the system will recommend the use of low beam.

4. If ambient brightness is too high, the system will recommend the use of low beam.

Note:

- Under severe weather conditions such as rainstorm, the system's function will be reduced due to the influence of visual range and clarity. The driver can choose whether to enable this function according to the specific situation.

- ▲ Attention:** - You should not block the view of the multifunction camera (located above the front windshield) while using the vehicle. Dirt on the front windshield in the field of view will cause the system to fail to function properly. Please pay attention to wiping and cleaning!
- If the radius of the curve is too small when you are driving on the curve road, the system will not be able to give a normal warning!
 - The system only provides sound and image warning, and does not actively interfere with the vehicle's track, so when the warning occurs, the user needs to judge and adjust the driving route!
 - When there is severe weather such as rainstorm, snow, fog, or the lane line is not clear enough to distinguish, the system's function will be affected, resulting in the failure of normal warning!
 - In the event of disassembly and installation of multi-function cameras, collision of vehicles or system function decline or abnormality, please be sure to contact JAC authorized after-sales service store for professional calibration of multi-function cameras.

1

2

3

4

5

6

7

8

9

10

11

12

Blind spot monitoring system*

The blind spot monitoring system monitors the blind area of the driver's side field of vision through two rear millimeter-wave radars. When a vehicle appears in the area and the warning conditions are met, the alarm lamp on the corresponding external rearview mirror reminds the driver that there is an approaching vehicle behind him. Please do not change lanes to avoid the risk of collision.

The blind spot monitoring system is equipped with corresponding hysteresis function:

The function can be activated when the vehicle speed exceeds 15km/h.

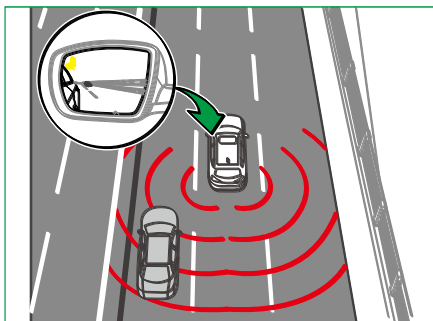

ON/OFF

The blind spot monitoring function can be turned on and off by clicking the "Vehicle control-Driving assistance" blind spot monitoring system switch in MP5.

The system displays the working status through the indicator  on the instrument. Yellow indicator is on when the system fails.

Alarm types

Alarm types of blind spot monitoring system function include standard alarm and enhanced alarm:

1. Standard alarm: when an alarm message is generated and the corresponding turn lamp of the vehicle is not lit, it is a standard alarm. At this time, the alarm indicator at the external rearview mirror is always on to remind the driver of the other vehicle on the rear and side of your vehicle.

2. Enhanced alarm: when an alarm message is generated and the corresponding turn lamp of the vehicle is on, it is an enhanced alarm. At this time, the alarm indicator at the external rearview mirror flicks.

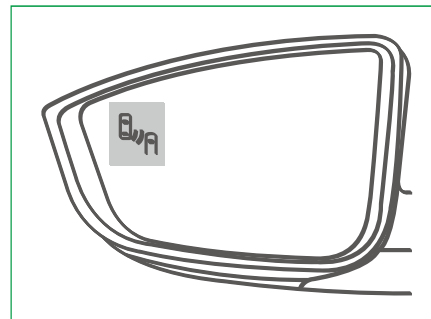

Alarm condition

1. When the vehicle moves forward at a speed greater than 15km/h and other vehicles approach or exceed the vehicle in the adjacent lane within 50m behind the side, the system will alarm.
2. When the vehicle is overtaking a target one at a relative speed of less than 15km/h, it enters the blind spot of the vehicle, and the system will give an alarm.

**Note:**

●The function of blind spot monitoring system is mainly applied to the urban and high-speed road conditions in normal weather. In some special working conditions, the accuracy of the system alarm cannot be guaranteed. The driver can choose whether to enable the function according to the specific situation, such as rainstorm and snow, sand and stone pavement, sprinkler pavement and grass pavement.

▲**Attention:** - The blind spot monitoring system is not applicable in all cases. The system does not actively interfere with the vehicle's traveling track and cannot replace the driver. Even if the system is in the running state, the driver still needs to drive carefully and make judgment to avoid danger!

- If the radius of the curve is too small when you are driving on the curve road, the system will not be able to give a normal warning!
- Severe weather conditions, such as heavy rain, snow, etc., will lead to a decline in the system function, in this case, the relevant target will not be detected by the system or detected too late!
- Blind spot monitoring system can not guarantee 100% detection of conventional vehicles (such as: cars, trucks, small power motorcycles, electric vehicles or bicycles) in the blind area, so the driver still needs to drive and judge carefully to avoid danger!

▲**Attention:** - When the rear millimeter-wave radar is subjected to strong vibration or impact, or the rear bumper is subjected to impact and deforms, the calibration of the rear radar will be affected, which will reduce the system performance or increase the leakage and false alarm. At this time, it is necessary to contact JAC authorized after-sales service store for professional inspection and calibration!

- The rear millimeter-wave radar requires special performance to detect relevant targets. When it is affected by the environment, detection will be interfered with, resulting in performance degradation, such as in the electric field or the target itself!
- The rear millimeter-wave radar is mounted on both sides of the rear bumper of the vehicle, and there should be no obstacle within the view of the radar sensor.
- The rear bumper should be kept clean at all times to avoid being covered by snow or dirt, which may affect the system's function!

1

2

3

4

5

6

7

8

9

10

11

12

Reversing assist system*

The reversing assist system monitors the blind spot of the driver's side visual field through the side rear radar to realize the reversing assist function for the vehicle.

When the vehicle is reversing vertically in a crowded parking lot, there is a blind area on both sides of the vehicle. The system can monitor the motor vehicle, non-motor vehicle or pedestrian on rear side that have potential risk of side collision with the vehicle, and provide the driver with necessary audible and visual alarm information through the external rearview mirror and instrument.

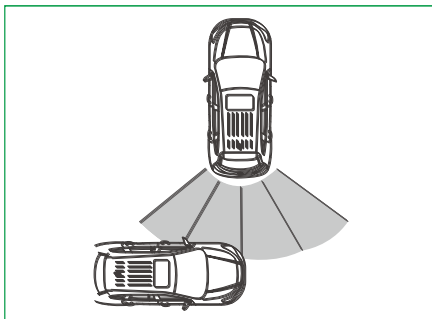

ON/OFF

The reversing assist function can be turned on and off by clicking the "Vehicle control-Driving assistance" reversing assist system switch in MP5.

The system displays the working status through the indicator  on the instrument. Yellow indicator is on when the system fails.

Alarm types

When the alarm condition of the reversing assist system is reached, the alarm indicator  of the external rearview mirror flashes and the instrument buzzes.

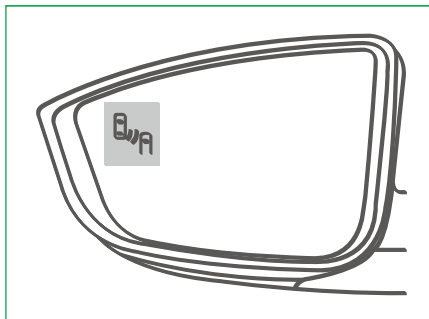

Note:

- The function of reversing assist system is mainly applied to the scene of reversing out of the garage in normal weather. In some special working conditions, the accuracy of the system alarm cannot be guaranteed. The driver can choose whether to enable the function according to the specific situation, such as rainstorm and snow.



▲ Attention: - Reversing assist system can not guarantee 100% detection of conventional vehicles (such as: cars, trucks, small power motorcycles, electric vehicles or bicycles) in the blind area, so the driver still needs to drive and judge carefully to avoid danger even the system is in operation!

- Severe weather conditions, such as heavy rain, snow, etc., will lead to a decline in the system function, in this case, the relevant target will not be detected by the system or detected too late!
- The rear millimeter-wave radar requires special performance to detect relevant targets. When it is affected by the environment, detection will be interfered with, resulting in performance degradation, such as in the electric field or the target itself!
- When the rear millimeter-wave radar is subjected to strong vibration or impact, or the rear bumper is subjected to impact and deforms, or the rear millimeter-wave radar is disassembled and assembled by the unprofessional person, the calibration of the

rear radar will be affected, which will reduce the system performance or increase the leakage and false alarm. At this time, it is necessary to contact JAC authorized after-sales service store for professional inspection and calibration!

- The rear millimeter-wave radar is mounted on both sides of the rear bumper of the vehicle, and there should be no obstacle within the view of the millimeter-wave radar sensor.
- The rear bumper should be kept clean at all times to avoid being covered by snow or dirt, which may affect the system's function!

Drive cautiously

Drive cautiously and ask the driver to do the following:

1. Fasten your seat belt.
2. Keep the sufficient distance. Because it is impossible to predict when the front vehicle will suddenly brake or turn.
3. The driver should be focus on driving and be ready to respond to various conditions. Any distractions such as talking on the phone, reading or picking up from the floor can interfere with normal driving and cause accidents.
4. Avoid dangerous behaviors such as over-speed, high-speed turning and sudden steering.
5. No fatigue driving; no drunk driving; do not drive if you take drugs that lead to drowsiness.
6. If the left or right wheel of the vehicle leaves the main road due to mistakes, the following remedial measures shall be taken:
 - Stay calm and don't panic.

1

2

3

4

5

6

7

8

9

10

11

12

- Do not brake.
- Hold the steering wheel steady with both hands and keep control of the steering wheel.
- When appropriate, release the accelerator pedal and gradually reduce the speed.
- After the speed is reduced, the road surface can be driven if traffic and road conditions permit.

Various driving situations

Drunk driving

Drunk driving has become the primary cause of fatal road accidents. Alcohol can affect driver's judgment, muscle coordination, eyesight and attention, and cause serious and fatal traffic accidents.

Warning

- Drink driving is strictly prohibited.

Quick tire leak

When the vehicle tire is punctured, crashed into the road or the larger stones, the tire will quickly leak. Insufficient air pressure can also cause tire damage and rapid air leakage.

Rapid air leakage of the tires will greatly affect vehicle stability and safety, especially at high speeds.

Regularly check the tire pressure, wear and damage, and inflate the tire according to the specified air pressure and replace the tire regularly, which can effectively avoid the rapid air leakage of the tire.

When the vehicle is experiencing rapid air leakage and puncture during driving, please dispose of it as follows:

- Stay calm and don't panic.
- Hold the steering wheel steady with both hands and keep control of the steering wheel.
- When appropriate, release the accelerator pedal and gradually reduce the speed.
- Slowly brake until the vehicle speed is reduced to a safe speed, park the vehicle in a safe area and try to stay away from traffic jams.
- Open the hazard warning light and contact JAC authorized after-sales service store immediately.



Night driving

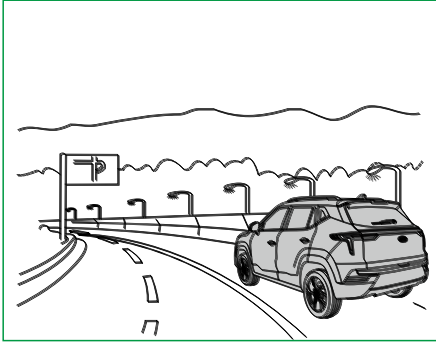

Subject to night vision problems and fatigue, driving at night is more dangerous than driving during the day.

Warning

- Drunk driving is strictly prohibited.
- Fatigue driving is strictly prohibited.
- Keep the inside and outside surfaces of the glass clean. Dirty glass will add to the dazzling light.
- Adjust the rearview mirror in the car to reduce the glare of the rear vehicle headlights.
- Headlamps may temporarily blind you, and it takes a second or even a few seconds for your eyes to adapt to the dark environment. When a dazzling glare is encountered, if the driver of the other party does not change the headlamp high beam to the low beam or the headlight of the other vehicle is not correct, the speed should be slowed down. Avoid looking directly into the car's headlights.

Warning

- The headlight can only illuminate the limited road ahead. Please slow down.
- Keep more distance from other vehicles.
- When the vehicle turns or in turning ways, look closely at the surrounding objects.
- When driving in remote areas, beware of animals.

1

2

3

4

5

6

7

8

9

10

11

12

Start and driving

City driving

When driving in heavy-traffic urban area, pay close attention to the behavior of other drivers and pay attention to traffic lights.

▲ Attention: To improve traffic safety in the urban area, please note:

- Fasten the seat belt and adjust to a comfortable driving posture;
- Understand the best route to your destination and know the driving route;
- It is best to drive at mid-to-low speed at an intersection or on a mixed traffic road, and prepare to stop at any time to prevent sudden changes of non-motor vehicles;
- Recognize traffic signs. When driving to the front of the intersection, slow down and select the correct route;
- Improve resilience. The broad vision and the calming changes are the key to safe driving.

Driving in rainy days and slippery roads

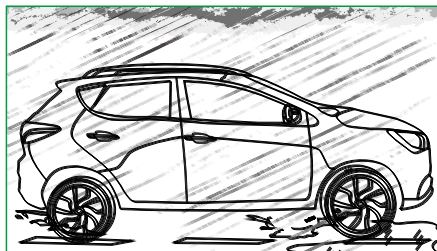

▲ Warning

- Before driving, make sure that the wiper works well; if the wiper blade appears to be unscrewed during scratching, or if the wiper area is left behind, or the tape is separated from the wiper blade, replace the wiper blade.
- Driving on rainy days and on slippery roads reduces road adhesion and deteriorates acceleration, braking, or steering. Drive with caution.

- When driving in rainy weather, visibility deteriorates. It is difficult to see pedestrians or road signs, traffic signals, road signs, and the edge of the driveway. Drive with caution.

- When the road is slippery, if the speed is too fast, the tire tread is flat, or the tire pressure is insufficient, it may be slippery. It is very dangerous. Please slow down.

- In emergency brakes, the poor performance of wet brakes may cause the vehicle to go sideways and cause an accident.

- Try to avoid driving in heavy rain.



Driving through deep water

Before wading, confirm the depth of accumulated water. The water depth must not be higher than the lower edge of the body.

Pass through long distance deep water areas with low speed. Pass through short distance deep water areas with fast speed. Do not park vehicle in water.

⚠ Attention:- If you drive through a deep water area with a long distance and water enters the front compartment, parts such as the motor controller may be damaged and the vehicle will not be able to travel.

- When wading, the electrical system components such as power batteries and motor controllers may be seriously damaged.
- Do not drive on salt-water roads due to corrosion of salt water.
- After the vehicle wading, if the passenger compartment is filled with water, please contact JAC authorized after-sales service store.

Ramp and mountain road driving



If you are often driving on steep slopes and mountain roads, please note:

- Keep the car in a good condition. Check all fluid levels as well as brakes and tires. These systems are very loaded when driving on mountain roads.
- Master downhill skills. Please slow down when going downhill. Do not turn off the power switch.
- When driving on a two-lane ramp or on a mountain road, do not change lanes as you like, and maintain proper speed.

- Be especially careful when crossing the top of the slope. There may be obstacles.
- Special warning signs may be seen on mountain roads. Such as long slope, overtaking area or prohibited overtaking area, falling rock area or corner, please drive carefully.

1

2

3

4

5

6

7

8

9

10

11

12

Start and driving

Ramp parking

Pull up the parking lever when stop on the ramp.

Using the following method to prevent the car from slipping:

– When the front face is facing downhill, turn the vehicle steering wheel to the side of the road, slowly drive the vehicle until the vehicle tires are close to the roadside to stop the vehicle from moving.

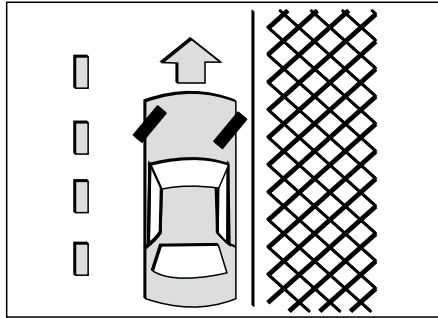

– When the front is facing uphill, turn the vehicle steering wheel to the opposite side of the roadside and slowly rewind the vehicle until the vehicle is close to the roadside to stop the vehicle from moving.

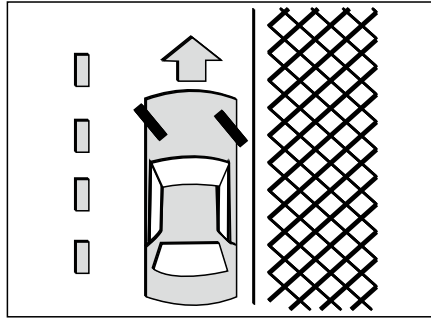

– When there is no obstacle on the roadside, turn the steering wheel of the vehicle in the opposite direction of the road to avoid the vehicle sliding to the center of the road.

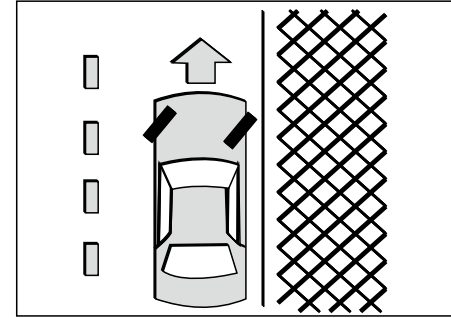



Winter driving

⚠ Warning

- Please drive carefully on slippery roads. The slippery road will increase the braking distance, thus is prone to slippage and spin. You should avoid rapid acceleration, emergency braking, and high-speed driving.
- The harsh driving environment in winter can increase tire wear or cause other problems. To reduce vehicle breakdown in winter, please refer to the following suggestions:

1. Prevent car door lock from freezing

In order to prevent the door lock from freezing, de-icing fluid or glycerin can be injected into the keyhole. If the keyhole is covered with ice, spray deicing fluid toward it to remove ice. If the inside of the keyhole is frozen, the key should be warmed up to melt the ice sheet. Be careful to avoid burns when warming up the keys.

2. Use the prescribed antifreeze cleaning fluid for window sprayer system

To prevent the window glass sprayer

system from freezing, use the antifreeze cleaning fluid according to the instructions on the container. JAC authorized after-sales service store can provide you with glass sprayer antifreeze cleaning fluid.

3. Do not allow ice or snow to accumulate at the bottom of the vehicle

In some cases, snow or ice may accumulate at the bottom of the vehicle, preventing the wheels from turning and turning. Before driving, check the bottom of the vehicle.

4. Prevent parking brake from freezing

In some cases, the snow or ice accumulating around the rear brake may freeze the parking brake. Please contact JAC authorized after-sales service store.

5. Equipment for emergency

According to weather changes, you need to carry appropriate emergency equipment, such as tire chains, tow straps and chains, flash lights, emergency spare tires, shovels, jumpers, window scrapers, gloves, floor coverings, work clothes, and carpets.

Highway hypnosis

On a gently stretched road, you can only see the same scenery. You can only hear the monotonous sound of tires or wind blowing through the car. This may make you sleepy. This is road hypnosis. Please observe the following related tips to avoid this phenomenon:

- Ensure that the vehicle is well ventilated and the interior environment is comfortable.
- Do not stare in one direction. Regularly check the mirrors and gauge information.
- If you feel sleepy, please stop and rest.

1

2

3

4

5

6

7

8

9

10

11

12





9

Emergency cases

● Emergency cut off the electrification system	174	1
● Tire	174	2
Tire repair	174	3
Tire damage precautions	174	4
Instructions of Tire Elf	175	5
● Jump start	179	6
● Power battery runs out	180	7
● Towing vehicle	180	8
● Get rid of the stuck car	182	9
● Mechanical unlock device	182	10
		11
		12

Emergency cases

Unlike conventional fuel vehicles, this vehicle has special hazards such as power batteries and high-voltage power. When the vehicle encounters an emergency such as a serious collision, fire, or flooding, appropriate measures must be taken to implement emergency measures to ensure that the occupants safety.

Emergency cut off the electrification system

During driving, in the event of an emergency, the motorized system must be switched off. Follow these steps:

- Press the power switch to power off.
- The personnel in the vehicle quickly left the vehicle.

Tire

Tire repair

Warning

- The Tire Elf is used to temporarily repair the pierced tires. After repair, the speed should not exceed 80km/h.
- After repairing the tire with the tire sealer, please immediately drive the vehicle to an authorized JAC authorized after-sales service store to inspect, repair, or replace the tire.

 **Attention:**- Avoid damage to the Tire Elf during storage or usage and keep the tire sealer toolbox dry.

- The Tire Elf is only for use in the vehicle. It can inflate the tires of the vehicle and check the tire pressure. Please use the on board 12V DC power supply to power the elf.

- Cases that no using the Tire Elf:

- Tire sealer is beyond its expiration date;
- The diameter or length of the broken tire exceeds 6mm;
- Tire edges are broken ;
- After driving the vehicle when the tire pressure is extremely low;
- Tire inside or outside is our from the hub;
- Wheel hub is broken;
- Two or more tires leak.

Tire damage precautions

If the vehicle tires are damaged and cannot continue driving, follow the steps below and contact an authorized JAC authorized after-sales service store as soon as possible.

1. Turn on the hazard warning flash light.
2. Park the vehicle in a safe area with a solid level of ground and a small traffic volume.
3. Pull up the parking switch and power off the vehicle.
4. Get all passengers off and stand in a safe place.
5. Put the warning triangle about 100m behind the car; 150m behind the car on the highway.

Violation of these safety precautions may result in damage to the vehicle or personal injury.



Instructions of Tire Elf

The Tire Elf contains an air pump and a bottle of liquid. When using Tire Elf, please pay attention to the following safety issues:

- It is only used for vehicle tires of this model. If you repair other tires, they may explode due to compressed gas, causing serious accidents or injuries.
- Please park the vehicle in a safe area so as not to affect the traffic. At the same time, you can use the tire elf in a safe state.
- Pull the EPB and make sure the vehicle does not move on its own.
- Do not try to pull out foreign objects that penetrate the tire, such as nails or screws, to keep the foreign body intact.
- When using the tire elf, you should always be careful.
- The operating time of the air pump must not exceed 10 minutes; otherwise there is a danger of overheating.
- When the tire sealer is about to expire, a new bottle of sealer should be replaced.

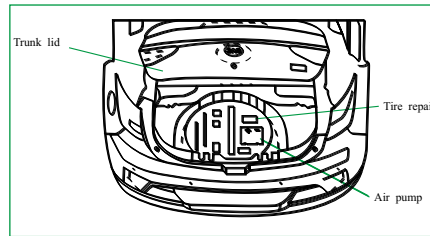

Steps for usage:

Step 1: Fill tires with air and tire sealer

1. Uncover the label ① marked with the maximum allowable speed on the air pump casing and stick it on the steering wheel or dashboard on the driver's line of sight.

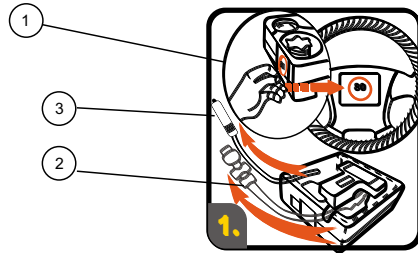

2. Take out the inflator hose ② and the power plug ③ in the air pump storage box.
3. Unscrew the orange cap ④ and the red cap ⑤ of the sealant bottle in the liquid retention cap of the sealant, and save the orange cap.

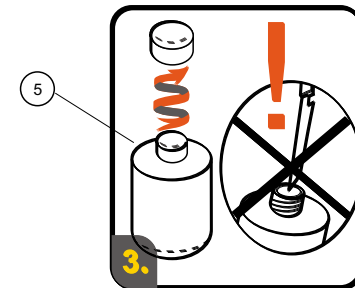
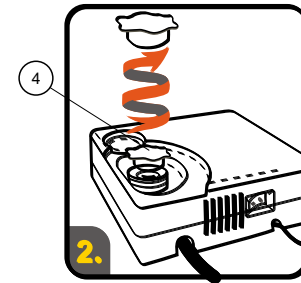

1

2

3

4

5

6

7

8

9

10

11

12

Emergency cases

4. Tighten the sealant bottle clockwise until it clicks into the fixing groove ⑥ until it is tightened.

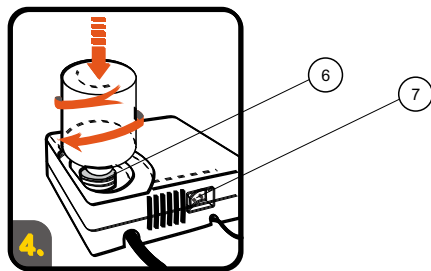

Warning

- Maintain the integrity of the bottle seal. After the bottle is screwed into the bottle holder, it will pierce the bottle sealing film.
- Avoid contact with the sealant fluid.

5. Unscrew the air valve core cap.

6. Unplug the protective cap at the end of the inflatable hose, and screw the pneumatic hose ② onto the valve core to ensure that the pressure relief valve ⑨ is fastened.

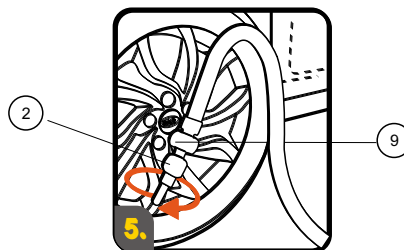

7. Make sure the air pump switch ⑦ is set to "0" (power off) and the pressure relief valve ⑨ is closed.

8. Plug the power plug ③ into the car power socket.

9. Power switch on.

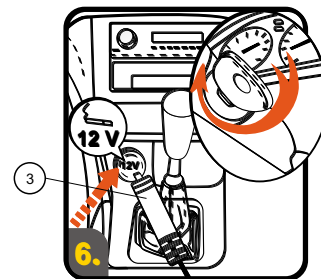

Warning

- Before inflating the tire, check the tire sidewall. If any cracking, bulging or similar damage is found, do not inflate the tire.



10. Switch the inflator pump ⑦ to the "I" (power on) position.

Warning

- When inflating, do not stand next to the tire. Observe the sidewall of the tire. If any cracks, bulges or similar damage occurs, close the air pump and open the pressure relief valve to vent the air. In this case, the continued use of the tire is prohibited.

Attention: When filling the tire sealant fluid through the tire valve core, the pressure may increase to 600 kPa, and the pressure will drop again after about 30 seconds. This is a normal phenomenon.

11. The tire pressure should be inflated to a value between minimum 180kPa and maximum 300kPa within 10 minutes. Close the inflator pump and read the tire pressure displayed on the pressure gauge ⑩. If it is greater than 180kPa, operate the following steps:

- Unplug the power plug from the car's power outlet.
- Quickly unscrew the inflatable hose from the tire valve core, install the protective cap and tighten the tire valve core cap.
- Do not unscrew the sealant bottle to avoid accidental leakage of sealant residue.
- Store the tire elf properly and use it again.

Warning

- If the tire pressure does not reach 180kPa within 10min, the tire may be seriously damaged and cannot be temporarily repaired. Use of the tire is prohibited. Please contact an authorized JAC authorized after-sales service store.

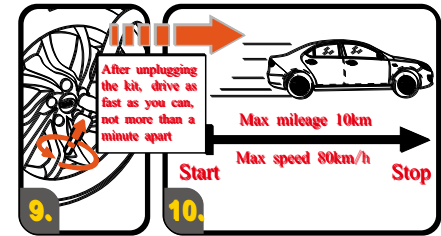

12. Immediately start the vehicle to drive about 3km so that the sealant fluid can seal the damage location. The driving time must not exceed 10 minutes and the speed must not exceed 80km/h.

Warning

- If a strong vibration, unstable steering performance, or noise occurs while the vehicle is in motion, lower the speed, park the vehicle in a safe area, and recheck the tire and tire pressure. If the tire pressure is lower than 130 kPa or the tire cracks, bulges or similar damage, continuing use of this tire is prohibited. Please contact an authorized JAC authorized after-sales service store.

1

2

3

4

5

6

7

8

9

10

11

12

Emergency cases

Step 2: Check tire pressure

Stop the vehicle after driving about 3km. Follow the following steps to check tire pressure:

1. Remove the protective cap from the end of the inflatable hose and screw it onto the leaky tire valve core.
2. Read the tire pressure on the pressure meter.

Warning

- If the tire pressure is lower than 130 kPa or the tire cracks, bulges or similar damage, continuing use of this tire is prohibited. Please contact an authorized JAC dealer.
- If the tire pressure is higher than 130kPa, please follow the steps below to adjust the tire pressure to the specified value (220±10kPa).

3. The air pump switch is set to "0".
4. Plug the power plug into the car power socket.
5. Power switch on.
6. The air pump switch is placed in the "I" position and the tire is inflated to the required air pressure.
7. Turn off the air pump and read the tire pressure. If the tire pressure is too high, use a pressure relief valve to release the tire pressure to the specified pressure value.
8. Pull the plug out of the socket, unscrew the hose and attach the protective cap, and screw on the tire valve core cap.
9. Do not unscrew the liquid bottle, please properly place the tire elf.

Warning

- After using the tire sealant liquid, the vehicle speed must not exceed 80km/h and the mileage must not exceed 200km. The damaged tire must be replaced as soon as possible. Do not continue driving if there is severe vibration, unstable steering, or noise during driving.

Note:

- When replacing damaged tires with authorized JAC authorized after-sales service store, please inform the used tire elf.
- It is recommended to replace the tire sealant and inflation hose.



Jump start

The jump-start is to provide power to the low-voltage electrical system through the external power supply after the lead-acid battery is depleted to start the vehicle. If the power battery is low, please charge it as soon as possible.

Warning

- Improper jump start is very dangerous and may result in personal injury or vehicle damage.
- There will be explosive gas hydrogen near the 12V lead-acid battery. Try to keep the 12V battery away from the flame.
- Do not expose to the electrolyte. The electrolyte is corrosive and may cause severe burns. If exposed, wash with plenty of water as soon as possible.
- Keep the 12V battery away from children.
- The jumper battery power must be a 12V system, otherwise it will damage the vehicle.
- When jump starting the vehicle, wear suitable goggles or industrial safety glasses. Do not tilt the 12V battery.

Jump start steps:

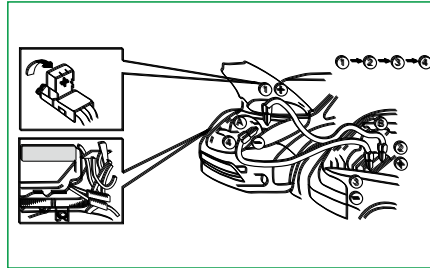

1. If the jumper battery is on another car B, place the 12V batteries of the two cars (A, B) as close as possible but not collide them.
2. Parking.
3. Turn off all non-essential electrical systems in B cars (such as headlights, air conditioners, etc.).
4. Place the key of B in the "LOCK".
5. Jump connection with the sequence ① - ② - ③ - ④ .

▲ Attention: The positive pole of car B is connected with the positive pole of car A, and the negative pole of car B is connected with the car body of A. It cannot be connected to the negative pole of car A. Otherwise, the car 12V lead-acid battery may be overheated or cracked, and the electrolyte may flow out.

1

2

3

4

5

6

7

8

9

10

11

12

Emergency cases

6. Start the B car, charging the B car lead-acid battery.
7. After the A car is started, carefully remove the jump cable in the order of ④ – ③ – ② – ① and keep the car A in the READY state for more than 20 minutes to charge the 12V battery.

▲ Attention: If the A car does not start, press the power switch, the vehicle is powered off and waiting 10s to start again. If the above steps are failed to start the vehicle, please contact JAC authorized after-sales service store immediately.

Power battery runs out

When the power battery meter shows "-- --", it means that the remaining power of the vehicle is very limited. Before the power battery runs out, stop the vehicle in a safe place and contact road assistance. Power off the vehicle and wait for rescue to avoid over discharging of the 12V battery.

Towing vehicle

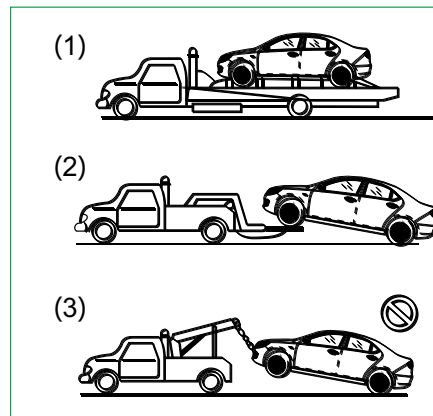

If you need to tow a vehicle, please contact JAC authorized after-sales service store or professional trailer service company. Incorrect trailer methods can damage the vehicle.

There are two common towing vehicle methods for you to choose from:

Tablet-type device — The operator mounts your vehicle on the truck. This is the best way to transport your vehicle, as shown in



figure (1).

Ride-wheel device - The tow crane is inserted into the bottom of the tire (front tire) of the vehicle with two arms. The wheel is lifted off the ground and the other two wheels are still on the ground. This is a feasible method for towing your vehicle, as shown in figure (2) .

This vehicle adopts front-wheel drive. If your vehicle cannot be towed by a flat-type device, the front wheel-type towing crane is used for the wheel-raising device. If due to front wheel damage, the front wheel of the vehicle must land when towing, the following provisions shall be complied with:

1. Disconnect the high voltage repair switch and unplug the three-phase connector between the motor and the motor controller.
2. Release parking.
3. Put the gear position in N.
4. The power switch is placed in the ACC gear to unlock the steering wheel.

Lifting devices—This type of tow crane uses metal cables with hooks at the ends,

which are hung on frame or suspension components, and the front of the vehicle is lifted off the ground by cables. In this way, the suspension or body of your vehicle may be seriously damaged. This method is not feasible, as shown in figure (3).

If there is no professional trailer towing vehicle, in the emergency trailer, please attach the ropes, chains and suspenders to the tow hook on the bottom of the front cabin of the vehicle. The position of the tow hook is shown in the following figure:

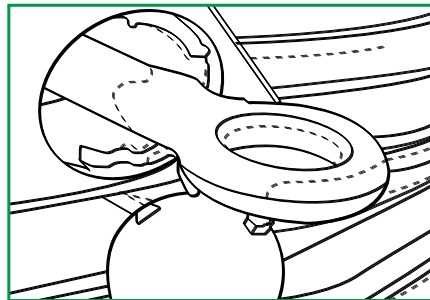

▲ Attention: - Before a vehicle is towed, it must be determined by a qualified service person whether it can be towed and disconnected.

- When the vehicle is equipped with an EPB and the trailer is in the power-on state, press and hold the parking switch until the switch indicator flashes to keep the EPB released.

1

2

3

4

5

6

7

8

9

10

11

12

Get rid of the stuck car

When your vehicle is stuck into snow, mud pit or other soft surface, please follow the steps below to get rid of:

1. Turn the steering wheel left or right to grind an area around the front wheel.
2. The vehicle repeatedly advances and retreats to reduce the idling of the wheels as much as possible and lightly step on the accelerator pedal.

If you still can't get out of trouble after trying several times, you need to tow the vehicle.

▲Attention: - Before getting out of the car, check if there are people or obstacles around the car, because during the operation, the car may suddenly move forward or backward, causing damage.

- In order to avoid damage to the motor and other parts, the following must be observed when getting out of a car trap:

- Do not step on the accelerator pedal during gear shifting.
- Avoid idling the wheels.
- If the wheels idles at high speed, the tire may be punctured, causing injury to you or other passengers, and the motor or other parts of the wheels may overheat, resulting in fire or other damage to the front compartment. When stumbling, you should try to avoid idling the wheels. Pay attention to the speedometer and prohibit the vehicle speed to exceed 48km/h or continuously idle for 30s.

Mechanical unlock device

If slow charge charging socket mechanical lock is damaged, it will cause the charging plug lock. Open the front cabin cover and use a hard rod to move the mechanical lock on the tail of the slow charge charging socket outward until you hear a click and the socket is unlocked. If it appears any abnormal, please contact JAC authorized after-sales service store immediately.



10

Exterior maintenance

● Exterior cleaning	184	1
Paint maintenance	184	2
Paint damage	185	3
Polishing and waxing	185	4
Window glass	186	5
Vehicle body bottom plate	186	6
Wheel	186	7
● Interior cleaning	187	8
● Anti-rust	188	9
Common causes of the rust	188	10
Common rusty areas	188	11
Humidity-induced rust	189	12
Rust prevention	189	

Exterior cleaning

In order to maintain the vehicle appearance, please clean it regularly. Park your car in a garage or in a cool place, or cover it with a car cover to prevent sun exposure. Be careful not to scratch the varnish when you cover or remove the hood. When you encounter the following situations, please clean it in time:

- After rain containing acidic substances;
- After driving on a coastal highway;
- When the surface of the car is contaminated with pollutants such as coal ash, dirt, bird droppings, leaves, metal scraps, and bugs.

▲Attention: When using any chemical cleaner or polisher, read all warnings and cautions on the label, and be sure to follow the label.

Some cleaning products are hazardous, such as corrosion, poisonous, flammable and explosive. Please use them carefully and keep them properly. Do not use the following supplies for vehicle cleaning:

- Gasoline
- Benzene
- Naphtha
- Carbon tetrachloride
- Acetone
- Coating thinner
- Turpentine
- Paint thinner
- Nail polish

Paint maintenance

In order to better protect the varnish of the vehicle and prevent rust and discoloration, the vehicle should be washed with warm or cold water at least once a month.

Clean the vehicle in time after driving in the wild. Pay particular attention to the thorough removal of all salt, dirt, mud, and other impurities.

If insects, tar, leaves, bird droppings, industrial pollutants, and similar deposits adhere to the varnish surface, it is recommended to use a warm, soap-free soap and rinse thoroughly with warm or cold water. Do not leave soap on the varnish surface.



Warning

- Do not flush the front compartment with water. This may cause water in the lamp and accessories to loosen and fall off, which may affect normal use. It may also cause high and low pressure connectors to enter water and damp, resulting in a short circuit. Severe electric shock or burn may occur, resulting in serious injury and even death.
- After washing the car, test the braking performance at a slow speed to see if it is affected. If the braking performance is affected, slow down and gently step on the brake pedal until the brakes are dry.

 **Attention:** - Do not use strong alkaline soaps, chemical cleaners, or hot water to clean the vehicle, and do not wash the vehicle when the body surface temperature is high.

- When using high-pressure water to clean the side windows and doors of vehicles, prevent water from seeping into the car and dampen the interior.

Paint damage

It should be repaired immediately if paint surfaces are with pits, cracks or deep scratches . Exposed metal is prone to corrosion and expensive to repair. Small pits or scratches can be purchased from JAC authorized after-sales service store to purchase repair materials. Large surface of damage can be repaired by JAC authorized after-sales service store.

Note:

- The joints and folds on the doors, trunk lids, and front covers are vulnerable to salty substances on the road. Please wash them regularly.
- Do not leave water spots on the body when you dry the vehicle.

Polishing and waxing

Regular polishing can clean the residue on the surface of the vehicle. After polishing, high-quality wax is used to protect the body paint.

Before polishing or waxing, clean and dry the vehicle.

 **Attention:-** Do not use a dry cloth to remove dust or dirt from the body to prevent damage to the paint.

- It is forbidden to use steam and alkaline soap to wash the vehicle; use of chrome-plating polishes and polished aluminum trims is prohibited, to prevent damage to the trim and wheels.

1

2

3

4

5

6

7

8

9

10

11

12

Window glass

To ensure a good sight, the window glass should be cleaned frequently. Please use the special glass cleaner provided by JAC authorized after-sales service store. When the vehicle is exposed to the sun, a thin film is easily formed on the glass surface, which can be removed with a glass cleaner and a soft cloth.

▲ Attention: Do not use sharp tools, corrosive cleaners, or chlorine-containing disinfectants when cleaning the inside of the window glass. Otherwise it can scratch or corrode the glass, damaging the electrical conductors, radio antennas, and post-defrost devices.

Vehicle body bottom plate

Corrosive substances used to remove snow and dust may adhere to the bottom of the vehicle. If it is not removed in time, even if it is treated with rust prevention, it will accelerate the rust on the under body parts. Thoroughly flush the bottom of the vehicle with the wheels at least once a month with warm or cold water, especially when driving in the wild and at the end of each winter. Because the dirt is not easily visible, the harm would be even more serious if they are not thoroughly removed after being wet with water. The lower edge of the door and the subframe have drain holes that should be clear and unblocked.

Warning

- After washing the car, test the braking performance at a slow speed to see if it is affected. If the braking performance is affected, slow down and gently step on the brake pedal until the brakes are dry.

Wheel

Wash the wheels regularly to keep them clean. Use a sponge filled with a mild soap or detergent to clean the wheels.

- When replacing the tire or cleaning the underside of the body, please clean the inside of the wheel.
- Regularly clean the wheel and wheel trim cover, especially after driving on salt-spraying roads in winter, wash the wheels promptly.
- If you often travel on salt-spraying roads in winter, it is recommended to wax the wheels to avoid corrosion.

▲ Attention: - Do not use aluminum or corrugated brushes containing strong acids or strong alkalis to clean aluminum wheels or wheel trims;

- Do not wash the wheel when the tire temperature is high;
- After the wheel is coated with cleaner, rinse it within 15 minutes.



Interior cleaning

Use a vacuum cleaner or a soft-bristle brush to remove dust and scum from interiors, plastic parts, and seats. Wipe the interior surface with a clean, damp cloth. You can purchase special cleaning supplies from JAC authorized after-sales service store.

- ▲ **Attention:** - Do not use benzene, thinner or any similar material to clean the interior.
- Small dust particles may abrade the leather surface, please remove it immediately. Do not use household soaps, car waxes, polishes, oils, cleaners, solvents, as they may damage the leather.
- Do not use glass cleaner or plastic cleaner to clean the instrument meter.

Fabric/carpet cleaning

Vacuum cleaners are often used to remove dust and scum. You can purchase special cleaning supplies from authorized JAC dealers.

- ▲ **Attention:** - Please read the instructions on the detergent label carefully.
- Wash the stain as soon as it cures.
- Use a clean cloth or sponge and use a soft brush when you encounter stubborn stains.
- In order to avoid leaving ring marks after decontamination, the entire area should be cleaned immediately, otherwise the ring marks will not be removed.

Cleaning fabrics with detergents

- Most stains can be removed with soda. Follow these instructions when cleaning:
- Clean the fabric where it is difficult to see, and make sure that the cleaning agent does not affect the color of the fabric.
 - Use a soft white cloth to remove liquid stains and use a vacuum cleaner or a soft-bristle brush to remove solid stains.
 - Spray the cleaning agent on a soft white cloth. Do not spray directly onto the fabric.
 - When cleaning the entire area, avoid wetting the fabric.
 - Clean from the seam to the stained spot to avoid leaving a circular mark.
 - Every time when the rag gets dirty, it should be replaced with another clean part.
 - After the stain has cleared, use a clean, soft, white, dry cloth to dry the area.

1

2

3

4

5

6

7

8

9

10

11

12

Special cleaning of fabrics

Stains from tomato sauce, coffee, eggs, fruit juices, milk, soft drinks, vomit, urine, or blood can be removed with soda. If urine and vomit are still smelly after cleaning, wash the area with soda and dry them. For the dirt caused by oils and greases, use special cleaning agents, and wipe off with a clean white cloth. Then wash it with cold water and dry it.

Cleaning the leather

Soak a soft cloth in warm water, rinse with a neutral soap or leather soap, dry it naturally, and do not dry it by heater. If you encounter stubborn stains, use a leather cleaner.

The use of oils, paints, solvent cleaners or abrasive cleaners, furniture polishes or shoe polishes is prohibited. After the leather is dirty, it should be cleaned immediately to prevent the stain from infiltrating and damaging the leather.

Cleaning the dashboard

Only use neutral soap and water to clean the dashboard surface. Do not use sprays containing silicon and paraffin, which may cause reflections in the front windshield, which may even under certain conditions seriously affect the visibility of the front windshield.

Cleaning internal plastic parts

Use only a soft cloth or sponge to wash with mild soapy water. Commercial cleaning agents may affect the surface gloss.

Cleaning the sealing strip for doors and windows

Apply grease to the seal with a clean cloth. Silicone grease enhances the durability and sealing of door and window sealing strips and keeps them from catching or "squeaking". If the weather is cold and humid, grease should be applied frequently.

Anti-rust

This vehicle adopts first-class design and advanced technology to prevent rust, but it prevents your vehicle from rusting for a long time and still needs your cooperation and help.

Parts of the bottom surface of the under body will rust, but they will not affect the reliability or function of these parts.

Common causes of the rust

The vehicle stays for a long time on accumulated salt, dirt and wet ground. The outer paint is scratched or the protective layer is worn by stones, gravel, and minor friction and dents, causing the metal to lose its protection and exposure to the outside.

Common rusty areas

If you live in an area where the vehicle is prone to rust, it is extremely important to prevent rust. Common causes for accelerating rust are ground salt, dust, chemicals, marine air, and industrial pollutants.



Humidity-induced rust

Vehicles are prone to rust in wet conditions.

The soil is slowly evaporating and moisture remains. If it contacts the vehicle, it can accelerate rust.

High temperatures can also quicken the rust to some fittings that cannot be properly ventilated and wet.

Clean the vehicle regularly to remove dirt or other accumulations.

Rust prevention

Keeping the vehicle clean: The best way to prevent rust is to keep the vehicle clean, remove foreign objects on the vehicle regularly, and keep the bottom of the vehicle clean:

– If you live in areas where vehicles tend to rust, such as salty highways, offshore, industrial pollutants, acid rain, etc. You need to strengthen measures to prevent rust. It is recommended to clean the bottom of the vehicle regularly.

– When cleaning the bottom of the vehicle, pay special attention to the parts at the bottom of the fenders and the hard-to-observe parts from the outside. To completely remove stains, only dampening the fill without thoroughly washing will accelerate rust. Water and steam at high pressure are particularly effective for removing soil and rusting materials.

– Clean the lower edge of the door, the sub-frame, etc. The drain hole should be kept open.

Keep paints and decorations in good condition: Scratches or damaged finishes should be immediately covered with a lacquer to reduce rust. If the metal is exposed, please go to JAC authorized after-sales service store for repair.

Damaged sheet metal parts: If the body needs to be repaired or replaced, use suitable anti-corrosion materials to prevent rust.

Interior maintenance: Moisture may accumulate under the carpet and corrode

the floor. Please check the carpet regularly and make sure the carpet is dry. If liquid spills or leaks out, it should be cleaned and thoroughly dried.

Keep the garage dry: Never park your vehicle in a heavily ventilated and poorly ventilated garage where the vehicle tends to rust. If the vehicle is cleaned in a garage or the vehicle comes with snow, ice, water, and dirt into the garage, the vehicle may rust.

1

2

3

4

5

6

7

8

9

10

11

12





11

Maintenance

- Basic requirements..... 192
- Regular inspection 192
 - Exterior inspection 192
 - Interior inspection 193
 - Front cabin and vehicle inspection..... 194
- Maintenance safety 195
- Cooling System..... 195
 - Coolant inspection..... 195
- Braking fluid 196
 - Recommended brake fluid type..... 196
 - Check the brake fluid level..... 197
- Front windshield washer fluid..... 197
- 12V Lead-Acid battery..... 198
- Windshield wiper blades 198
- Wiper blade replacement 198
 - Front wiper blades 198
 - Rear wiper blade..... 199
- Brake 199
- Fuse 200
- Key battery replacement 200
- Lights 202
- Wheels and tires 202

1

2

3

4

5

6

7

8

9

10

11

12

Basic requirements

In order to avoid breakdowns and keep the vehicle in good operating condition, maintenance is necessary, including regular maintenance and routine inspections:

Regular maintenance is the systematic inspection and confirmation of the vehicle after the vehicle has traveled for a certain period of time or mileage. Please refer to this vehicle's Warranty and Maintenance Manual for maintenance intervals and items.

Regular inspections are simple inspections and maintenance of the vehicle before and after each use of the vehicle.

Note:

- The vehicle must be regularly maintained.
- If the JAC maintenance personnel notifies that the vehicle needs to be repaired or maintained, your attention should be paid to timely maintenance.

Regular inspection

Users need to carry out regular vehicle inspections during the daily use of the vehicle. If abnormal sounds, vibrations, and odors are found during vehicle use, please contact the authorized JAC dealer.

Exterior inspection

The maintenance items listed here should be checked periodically:

Doors, front cabin cover and tailgates:

Make sure all door locks are safe, lubricate hinges, lock pins, roller connections and lubrication. Check after driving on salty roads or other roads with corrosive substances.

Car lights: Clean the headlamps before cleaning regularly to check if the direction of irradiation is normal; ensure that the front combination headlights, brake lights, reversing lights, turn signals, and other lights are all working properly and are firmly installed.

Wheel nuts: Check the wheels. If nuts

loose or fall off, tighten them.

Wheel rotation: It is recommended to rotate every 10,000 kilometers.

Tires: Check the tires for damage or excessive wear. If necessary, check the tire pressure with a pressure gauge and adjust all tire pressures to the specified values.

Four-wheel positioning: If the vehicle is misaligned or the tire is abnormally worn during driving, the vehicle may need to re-orient four wheels.

Windshield: Clean the windshield regularly. Check the glass at least every six months for cracks or other damage.

Wiper: If the wiper works abnormally, check the wiper blade for cracks or wear.



Interior inspection

The maintenance items listed here should be checked periodically:

Accelerator pedal: Check if the accelerator pedal works smoothly to ensure that it is not interfered with by the mat.

Brake pedal: Check whether the brake pedal works smoothly and ensure that it has a distance that can be moved up and down. If the brake pedal does not work properly, check the brake booster function. If the pedal feels soft or the vehicle braking time is extended, please contact JAC authorized after-sales service store.

Braking system: Check if the vehicle is deflecting when braking.

Parking brake: When the vehicle is parking on the ramp, check whether the vehicle can be maintained in a fixed position. If not, contact JAC authorized after-sales service store.

Seat: Check the seat adjustment device, such as front and rear seat adjustments,

seat backrest front and back adjustments, etc. to ensure smooth operation; check that all latches are secure; check that the headrests move up and down smoothly.

Seat belt: Check whether the various parts of the seat belt (such as the tongue, the buckle lock, and the retractor) are installed securely and operate smoothly; check the webbing for wear or damage.

Steering wheel: Check for heavy or abnormal sound when steering.

Warning lights and horns: Make sure all warning lights and horns are normal.

Front defrost vents: Turn on the air conditioner and check that the defrost vents are adequate.

Wiper and sprinklers: Check if the wipers and sprinklers are working properly and make sure that the wipers do not leave scratches on the window glass.

1

2

3

4

5

6

7

8

9

10

11

12

Front cabin and vehicle inspection

Cockpit Overview

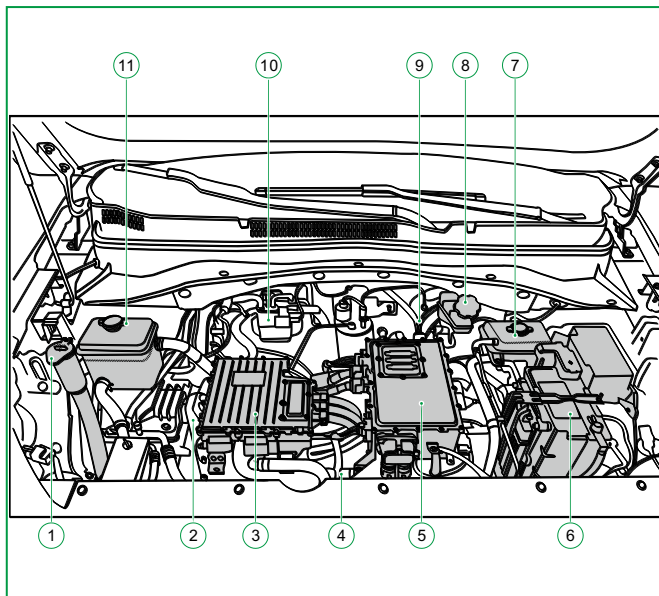

1. Washing liquid filling port
2. Air conditioning compressor
3. PCU
4. Driver motor + reducer
5. High voltage junction box
6. Battery
7. Cooling kettle
8. Brake fluid reservoir
9. Vacuum booster
10. ESC controller
11. Battery thermal management kettle

The items listed below should be checked frequently:

Brake fluid level: Make sure that the brake fluid level is between the MAX and MIN lines on the brake fluid pot.

Battery coolant level: Make sure the coolant level is between the MAX and MIN lines on the coolant pot.

Electrical drive coolant level: Make sure the coolant level is between the MAX and MIN lines on the coolant pot.

Wash liquid volume: Check the liquid volume and add if necessary.

Liquid leaks: Check for water or other liquid leaks at the bottom of the vehicle.

Water dripping from the air conditioner after use is normal.

Under body: Regularly clean the under body.

⚠ Attention: Before checking, please turn off the power switch. If the temperature of the front compartment is high, please do not check it.



Maintenance safety

Warning

- The vehicle's high voltage system is within 400V. After the vehicle is running, the temperature goes high. When you inspect or maintain the vehicle, you must take protective measures and observe the following:
 - Park the vehicle on a level road, pull up the parking lever, put the gear position in the N; prohibit the connection or disconnection of 12V lead-acid battery when the power switch is turned on.
 - Power switch off.
 - The cooling fan of the vehicle may be started at any time. Please disconnect the negative pole of the 12V lead-acid battery during maintenance.
 - For maintenance, loosen or remove loose clothing, remove accessories such as rings and watches, and wear protective glasses. Contact with live parts with keys or metal accessories can result in electric shock or burns.

- Do not maintain or disassemble, move, or replace the high-voltage components, wiring harnesses, and connectors by yourself. Otherwise, serious burns or electric shocks may result and serious injury or death may result.
- It is forbidden to enter under the car supported by the jack. If you go under the car, you must use a safety bracket.
- Do not allow children or pets to be exposed to vehicle fluids.
- When replacing bulbs, fuses, or lead-acid batteries, make sure the vehicle's charging plug is unplugged and the remote air-conditioning unit is off. Place the key in the ON block and then close it to prevent the power battery from charging the lead-acid battery.
- When connecting 12V lead-acid battery cables, attention must be paid to polarity. Do not connect the positive cable to the negative terminal or the negative cable to the positive terminal.

Cooling System

Coolant inspection

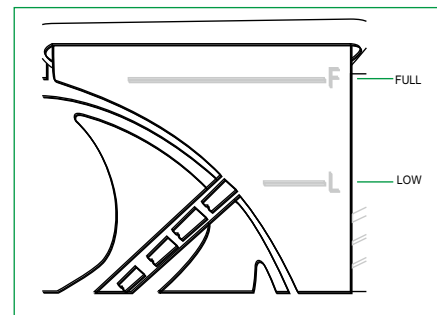

When checking the coolant level, the radiator temperature is the same as the ambient temperature. If the liquid level drops to or below "MIN," add cold liquid until the liquid level is between "L" (LOW) and "F" (FULL).

The cooling system is a closed system with little loss. The liquid level of the coolant is obviously reduced to indicate the possibility of leakage of the system. Please contact JAC authorized after-sales service store.

1

2

3

4

5

6

7

8

9

10

11

12

⚠ Warning

- When the radiator temperature is high, it is forbidden to open the filler cap to prevent serious burns due to steam or hot liquid being sprayed.
- After the power switch is turned off, the radiator cooling fan may continue to operate for a period of time. Do not approach it to avoid injury.

⚠ **Attention:** - When replacing the coolant, please contact JAC authorized after-sales service store.

- Use the same type of coolant as much as possible. If mixed, chemical reactions may occur, causing the coolant to fail.
- If coolant gets on the car, wash it thoroughly with water cleaned. Corrosive coolant can damage the surface of the vehicle washing solution. Do not add wash solution to more than three quarters of the volume

Braking fluid

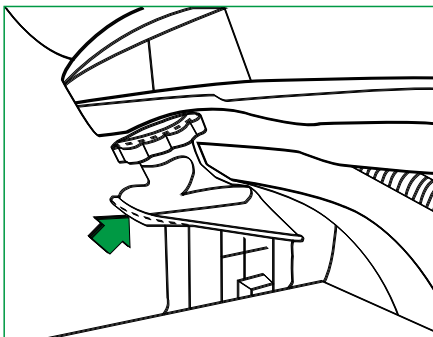

Recommended brake fluid type

DOT4 brake fluid is recommended.

⚠ Warning

- Be sure to add the correct type of brake fluid and it is not contaminated. Incorrect or contaminated (such as mineral oil) brake fluid may damage the seals of the brake system. In severe cases it may cause brake failure.
- Clean the lid and surrounding parts before you remove the brake fluid reservoir cap.
- Brake fluid is toxic and should be stored out of reach of children.
- Do not use brake fluid that has been exposed to air for long periods of time.
- When replacing and adding brake fluid, care should be taken not to splash brake fluid into the eyes. If you accidentally spill brake fluid into your eyes, rinse immediately with plenty of water and consult a doctor as soon as possible.



Check the brake fluid level

Check the brake fluid in the tank regularly. The liquid level should be between the "MIN" and "MAX" marks on the side of the reservoir. If the liquid level is at or below the "MIN" mark, please add the brake fluid to a level close to "MAX" without excessing.

The brake fluid level will decrease as the mileage increases.

It is a normal phenomenon.

If the brake fluid level is too low, the brake system fault warning light (⚠) will illuminate; if brake fluid is added frequently, contact JAC authorized after-sales service store.

⚠ Attention: If the brake fluid splashes on the car, rinse it thoroughly with water. Brake fluid is corrosive and can damage the surface gloss of the vehicle.

Front windshield washer fluid

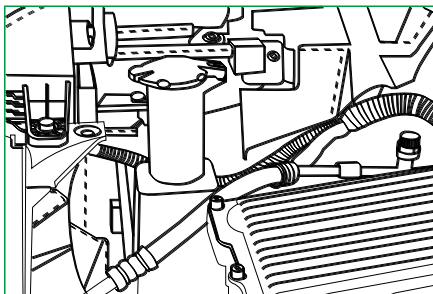

Regularly check the level of the glass wash solution and add it in timely. In cold conditions, the washing solution freezes and swells, damaging the washer fluid reservoir. It is forbidden to add washer fluid to more than three-quarters of the volume.

⚠ Attention: - Use special detergent as much as possible.

- If the temperature is likely to fall below 0°C, a front windshield washer fluid with antifreeze must be used.

- Do not add radiator antifreeze to the front windshield washer fluid reservoir. Radiator antifreeze can damage the front windshield washer system and vehicle paint.

1

2

3

4

5

6

7

8

9

10

11

12

12V Lead-Acid battery

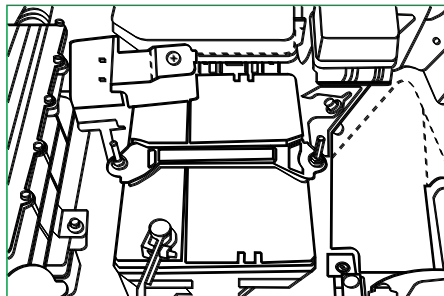

The vehicle is equipped with a maintenance-free 12V lead-acid battery. If you need to replace, please use the same specifications of lead-acid batteries.

Storage of 12V Lead-Acid battery

If the vehicle is left for a long time, disconnect the negative pole of the battery.

Jump start

The jump-start is to provide power to the low-voltage electrical system through the external power supply after the lead-acid battery is depleted to start the vehicle. If the battery power is low, please charge it as soon as possible. For details, see Chapter IX Emergency cases.

Windshield wiper blades

▲ Attention: - When operating the wiper at low temperatures, check whether the wiper is frozen on the windscreen, otherwise the motor may be burnt.

- Regularly inspect the surface of the blade to see if any dirt or other contaminants can condense. Otherwise it may not be clean.
- Due to ice or other obstacles on the glass during work, the wiper stops working, which may cause the wiper motor to burn out.
- Do not use a wiper when the surface of the windshield glass is dry, otherwise it will scratch the glass and cause the blade to wear prematurely.

Wiper blade replacement Front wiper blades

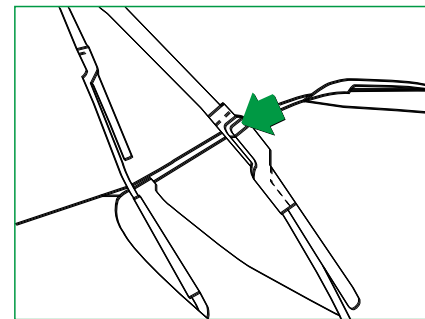

1. Make sure the front wiper is closed and the wiper arm is stationary (closed).
2. Lift the wiper arm, press the lock button, and pull the wiper blade out along the wiper arm.
3. Slide the new wiper blade into the wiper arm until you hear the click.
4. Check whether the wiper blade is fixed in place and fold the wiper arm back to the front windshield.



Rear wiper blade

To replace the rear wiper blade, lift the wiper arm away from the rear windshield to remove and replace the wiper blade.

Note:

- The wiper arm can only be turned over if the hood of the front hood is completely closed, otherwise the front hood will be damaged.
- Do not fold back the wiper arm before inserting the new wiper blade, otherwise the front windshield may be damaged.

Warning

- If the wiper scratches, the wiper should be cleaned with window cleaner. In the case of heavy stains (such as insect residues), the wiper blades can also be cleaned with soft sponges or rags, otherwise there is a risk of accidents!

Brake

If there is any abnormal happened, please contact JAC authorized after-sales service store immediately.

Warning

- It is forbidden to adjust the brake pedal height and repair the brake system components. It may affect the braking performance of the vehicle and cause serious accidents and personal injury. If you need to adjust, please contact JAC authorized after-sales service store.
- The vehicle is equipped with front/rear disc brakes.
- The disc brake clearance is automatically adjusted and the friction plate has a wear warning. When the friction plate needs to be replaced, the friction plate will generate high-frequency scratches when the vehicle runs and the brake pedal is depressed. When the wear is severe, there will always be scratching even if the brake pedal is not depressed.

- Under certain driving conditions and weather conditions, slight squeaks, sharp sounds or other noise may be occasionally heard during braking, which is normal and does not affect the performance of the braking system.

1

2

3

4

5

6

7

8

9

10

11

12

Fuse

Each circuit is equipped with a fuse to prevent circuit damage caused by a short circuit or overload. If there is a fuse blown, please contact JAC authorized after-sales service store to determine the cause, check the system and replace the fuse. Use a fuse with the same fuse current when replacing the fuse.

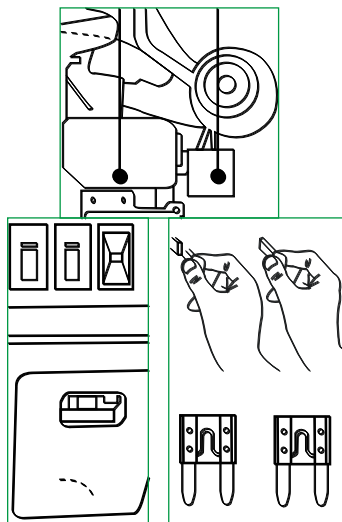

If any electrical equipment does not operate, check the fuse in the electrical box:

1. Turn off the power switch.
2. Open the front cover and electrical box and use the inner box clamp to pull out the corresponding fuse and check if it is blown.
3. If the fuse is found to be blown, check the other fuses.
4. Install a new fuse. The fuse should fit well into the seat slot. If there is no spare fuse, you should purchase a fuse of the same size or remove the low amperage fuse from other temporarily unused accessories (such as the car power supply).

▲ Attention: - When replacing a fuse, you need to use a new fuse with the same or a slightly lower specification. Do not use wires or fuses with a high fusing current, otherwise serious damage may occur and there is a risk of fire.

- A blown fuse indicates a circuit failure. If the fuse blows immediately after replacement, it indicates that the circuit has a serious fault. Please contact JAC authorized after-sales service store.

Key battery replacement

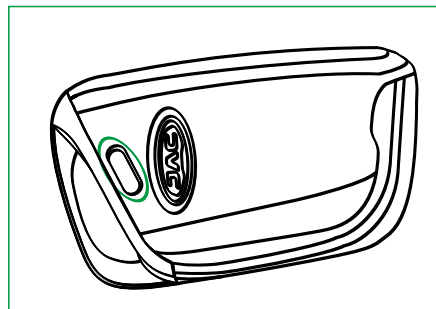

If the light on the key does not light or must be near the vehicle transmitter to remote control, replace the battery as follows:

1. Press the mechanical key to remove the key and pull out the mechanical key.

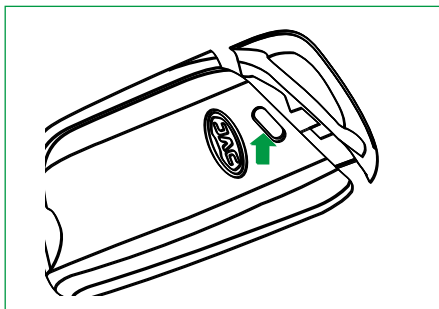

2. The upper shell buckle of the shell is gently tilted, and then the shell is opened at the gap of the shell.

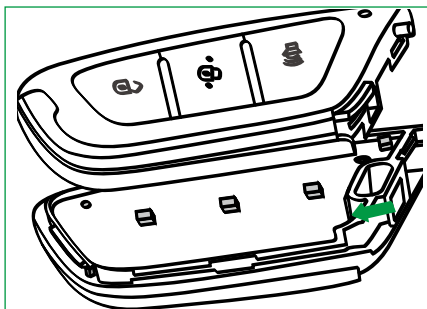

4. Replace the battery (the battery is facing down).

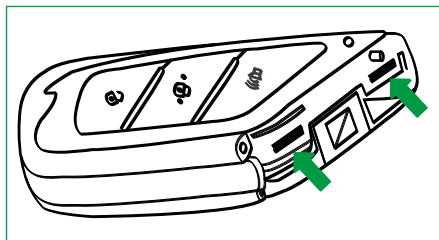

3. Remove the circuit board.

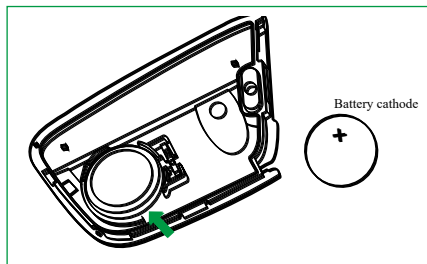

5. Follow the opposite sequence of the disassembly to assemble.

Note:

- Press the power switch quickly to place the power switch in the LOCK gear;
- The personnel in the vehicle quickly left the vehicle.

1

2

3

4

5

6

7

8

9

10

11

12

Lights

Warning

- Do not expose the removed lamp for a long time to prevent dust, water vapor, smoke, etc. from entering the lamp and affecting performance.
- Halogen bulbs (brake lights, turn signals) are sealed with high-pressure halogen gas, which may burst when the bulb glass case is scratched or dropped.
- While handling bulb, please hold the base part only to avoid contact with glass. Otherwise it may affect lamp life or performance.
- There is no need to adjust the focal length after lamp replacement. If necessary, please contact JAC authorized after-sales service store.

Wheels and tires

 **Attention:** - The lack of proper maintenance and use of tires is very dangerous; tires must have the correct inflation pressure to work effectively.

- Vehicles that are overloaded can cause tires to overheat, leak air, and cause serious accidents.
- Insufficient tire inflation is as dangerous as tire overload. Regularly check all tires while cold and maintain the recommended air pressure.
- Do not inflate the tire excessively to prevent it from being scratched, punctured or burst due to sudden collisions (such as bumps).
- Worn tires with worn or damaged tire treads can cause accidents.

Note:

- Tire information is printed on the sidewall of the tire; a tire pressure label is attached below the B-pillar on the driver's side, indicating the correct inflation pressure in the cold state.

 **Attention:** If the tire pressure is insufficient.

It will cause:

- Excessive deflection
 - Tire overheat
 - Tire overload
 - Premature or irregular wearout
 - Bad manipulation
 - Low economic performance
- Excessive inflation of the tire will result in:
- Abnormal wearout
 - Bad manipulation
 - Poor ride comfort
 - Unnecessary damage due to rough roads

Tire inspection

Check cold tire state pressure at least once a month. Cold state means that the vehicle is stopped for more than 3 hours or the driving distance does not exceed 1.6km. You can use tire elf to check the tire pressure. If the pressure is lower than the recommended pressure, please adjust. For details, refer to Chapter IX Emergency Response.

Tire repair

The tire elf can temporary repair the smaller piercing diameter tires. For details, refer to Chapter IX Emergency Response.



Tire and wheel inspection and transposition

If abnormal wear of the tire is found, it means that the wheel needs to be replaced and further inspection. Please contact JAC authorized after-sales service store.

The purpose of changing the wheels on a regular basis is to make all the tires of the vehicle evenly worn.

When the wheel is transposed, it must be transposed in the correct transposition mode as shown.

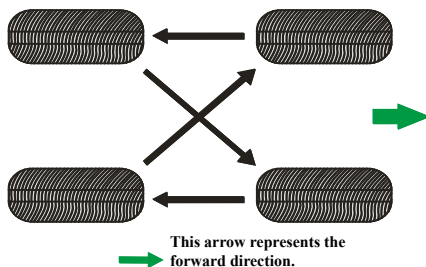

After the wheels are replaced, the air pressures of the front and rear tires are adjusted according to the tire pressure. Make sure all wheel nuts are correctly tightened.

⚠ Attention: Remove any rust or dirt from the wheel and wheel connection parts, prevent the wheel nut from loosening after a period of time, causing the wheel to fall off and cause an accident.

When to replace the new tire

It can be judged based on the tread wear indicator. When the tread wears to 1.6mm or less, the tread wear indicator appears.

New tires need to be replaced if:

- Tire cord or fabric is exposed.
- Tire cord and fabric can be seen in cracks in the tread or sidewalls.
- Tire bulge, uplift or stratification.
- The tire is punctured, scratched or otherwise damaged, the degree of which is difficult to repair.

Buy new tire

Check the tire information, learn about tire model and size, and purchase tires of the same size.

Replace the tire

Wheels should be replaced when bent, cracked, severely corroded or corroded. If the wheel nuts are often loose, the wheels, wheel bolts and nuts should be replaced.

⚠ Attention: Please use new wheels, wheel bolts, and nuts of the same specifications as the original wheels. Do not mix them. Doing so can damage the vehicle or even cause accidents and personal injury.

Wheel alignment

If you notice abnormal tire wear or vehicle deviation and bumps when driving on a flat surface, you may need to check the wheel alignment.

1

2

3

4

5

6

7

8

9

10

11

12





12

Technology data

● Vehicle identification	206
Position of vehicle identification number (VIN).....	206
● Drive motor model.....	207
● Microwave window	207
● Vehicle dimension parameters	208
● Tire size and cold inflation pressure	208
● Fluid specifications and dosage	208
● Positioning parameters of front&rear wheels(empty load).....	209
● Wear limits of brake friction plates.....	209

1

2

3

4

5

6

7

8

9

10

11

12

Vehicle identification

Position of vehicle identification number (VIN)

There are several vehicle identification numbers on the vehicle, and the following 10 are the most common:

1. Located on the dashboard in the lower left corner of the windshield, VIN can be seen through the windshield.

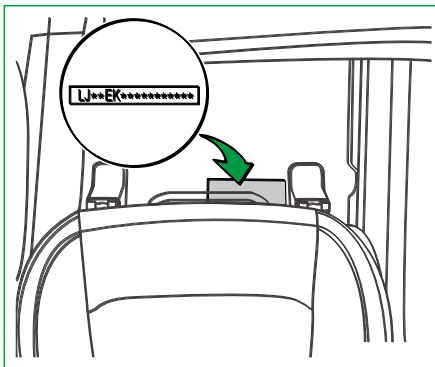
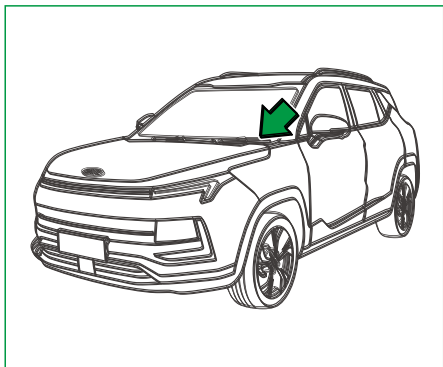

2. Located under the front passenger seat, VIN can be seen by pushing seat backward and removing carpet.

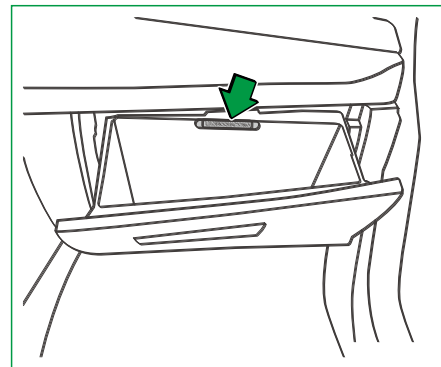

3. Located in the vehicle storage box, you can see VIN by opening the storage box. The remaining VIN labels are on the following locations:

4. Inside the front hood
5. Front side of right-front door inner panel
6. Lower side of left column B
7. Front side of left-front door inner panel
8. Upper side of tailgate inner panel
9. ECU electronic data
10. Multi-media display screen electronic data



Drive motor model

Drive motor model and number, located on the motor housing.

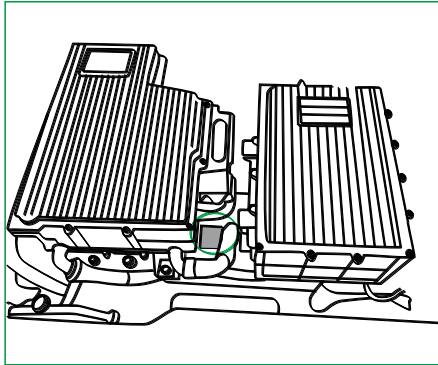

Microwave window

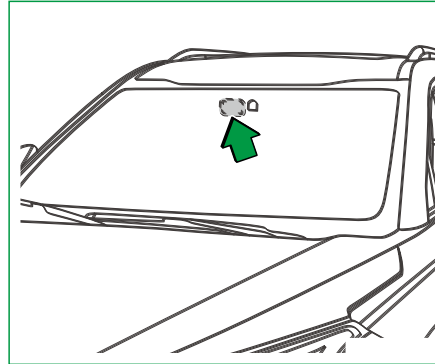

Vehicle's microwave window is located horizontally in the center and vertically in the upper part of the front windshield. The electronic identification of vehicle should be stuck on the center of microwave window, and the distance between electronic identification's boundary of vehicle and microwave window's boundary of windshield should not be less than 10mm. This electronic identification contains relevant information about the vehicle.

1

2

3

4

5

6

7

8

9

10

11

12

Vehicle dimension parameters

Items		Parameters
Size	Outside dimension (L×W×H)mm	4410×1800×1660
	Wheelbase(mm)	2620

Tire size and cold inflation pressure

Tire specifications	225/45 R18
Tire cold state inflation pressure (kpa)	230±10

Fluid specifications and dosage

Name	Specification	Quantity per unit
Electric drive coolant	OAT LEC-II	3.4L
Battery coolant	OAT LEC-II	8.4L
Reduction gear oil	SAE 75W- 90 API GL- 4	2.1±0.1L
Braking fluid	DOT4	0.78L
Refrigeration oil	RL68H	



Positioning parameters of front&rear wheels(empty load)

Items	Positioning parameters	Parameter values
Front wheel	Wheel's camber angle	$15' \pm 30'$
	Kingpin's inclination angle	$13.4^\circ \pm 30^\circ$
	Kingpin's caster angle	$4.6^\circ \pm 30^\circ$
	Wheel's toe-in angle	$12' \pm 6'$
Rear wheel	Wheel's camber angle	$-60' \pm 30'$
	Wheel's toe-in angle	$12' \pm 10'$

Wear limits of brake friction plates

Item	Unit	Parameter
Standard thickness of front brake pad	mm	10
Minimum thickness of front brake pad	mm	2
Standard thickness of rear brake pad (EPB)	mm	10.2
Minimum thickness of rear brake pad(EPB)	mm	2
Travel of brake pedal	mm	126
Free travel of brake pedal	mm	3-8

